

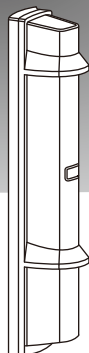

INSTALLATION INSTRUCTIONS



PHOTOELECTRIC DETECTOR Smart Line™ series



Multilingual instructions

Visit to the Web site to find various language versions.

<https://navi.optex.net/manual/08808/>



Model	Detection range
SL-200QN	60m/200ft.
SL-350QN	100m/350ft.
SL-650QN	200m/650ft.

FEATURES

- Quad high power beams
- Smart design
 - Slim body design
 - Easy-to-see vivid interior color for optical alignment
 - IP65 waterproof structure
- Viewfinder with 2X magnification
- Various options (refer to page 12)
(HU-3, ABC-4, BC-4, CBR-4, PSC-4, BAU-4)
- Beam interruption adjustment function
- Tamper function
- UL/c-UL Listed

CONTENTS

① INTRODUCTION	
1-1 BEFORE YOUR OPERATION	1
1-2 PRECAUTIONS	2
1-3 PARTS IDENTIFICATION	2
② INSTALLATION	
2-1 SEPARATING	3
2-2 WIRING	3
2-3 TERMINAL	4
2-4 WIRING DIAGRAM	4
2-5 WIRING DISTANCE BETWEEN POWER SUPPLY AND DETECTOR	4
2-6 WALL MOUNTING	5
2-7 POLE MOUNTING	6
2-8 MOUNTING IN THE BEAM TOWER	7
2-9 INSTALLATION EXAMPLE AT PARTICULAR CASE	7
③ FUNCTION SETTING	
3-1 BEAM INTERRUPTION ADJUSTMENT	8
④ OPTICAL ALIGNMENT	
4-1 OPTICAL ALIGNMENT FOR UPPER AND LOWER BEAM	8
⑤ OPERATION CHECK	9
⑥ OPTIONAL SETTING	
6-1 HEATER UNIT HU-3 (OPTION)	10
⑦ DIMENSIONS	10
⑧ TROUBLESHOOTING	11
⑨ SPECIFICATIONS	11
⑩ OPTIONS	12

1 INTRODUCTION

1-1 BEFORE YOUR OPERATION

- Read this instruction manual carefully prior to installation.
- After reading, store this manual carefully in an easily accessible place for reference.
- This manual uses the following warning indications for correct use of the product, harm to you or other people and damage to your assets, which are described below. Be sure to understand the description before reading the rest of this manual.

	Failure to follow the instructions provided with this indication and improper handling may cause death or serious injury.
	Failure to follow the instructions provided with this indication and improper handling may cause injury and/or property damage.



This symbol indicates prohibition. The specific prohibited action is provided in and/or around the figure.



This symbol requires an action or gives an instruction.

	Do not use the product for purposes other than the detection of moving objects such as people and vehicles. Do not use the product to activate a shutter, etc., which may cause an accident.	
	Do not touch the unit base or power terminals of the product with a wet hand (do not touch when the product is wet with rain, etc.). It may cause electric shock.	
	Never attempt to disassemble or repair the product. It may cause fire or damage to the devices.	
	Do not exceed the voltage or current rating specified for any of the terminals during installation, doing so may cause fire or damage to the devices.	
	Do not pour water over the product with a bucket, hose, etc. The water may enter, which may cause damage to the devices.	
	Clean and check the product periodically for safe use. If any problem is found, do not attempt to use the product as it is and have the product repaired by a professional engineer or electrician.	

1-2 PRECAUTIONS

Do not install the unit on an unstable surface.

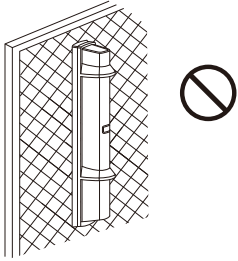

Do not install the pole in a location where sufficient stability can not be ensured.

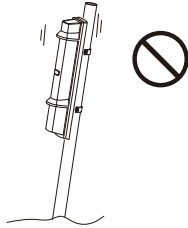

Do not install the unit in a location where trees, leaves, or other objects that may swing in the wind and block the beam.

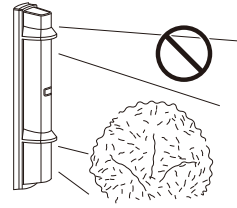

Do not install the receiver in a location where it is exposed to direct sunlight.

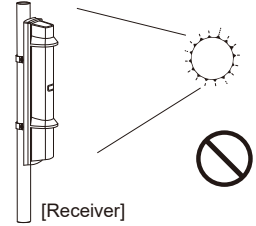

Do not allow the infrared beam from another detector to reach the receiver.

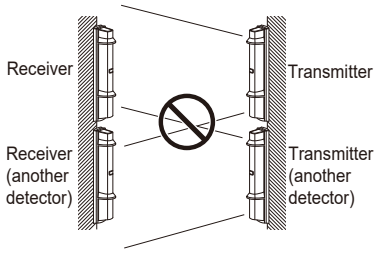

Install the unit at a height where an object can be detected without fail.

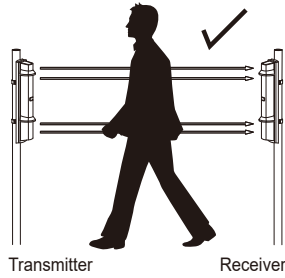

The pole size should be $\phi 34 - 48$ mm ($\phi 1.34 - 1.89$ inch).

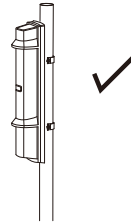

Install the unit at least 1 m (3.3 ft.) away from the wall or fence that may be running parallel to the beam.

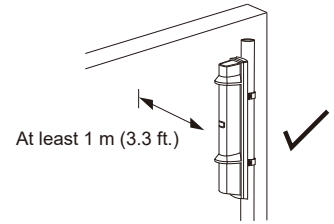

This symbol indicates prohibition.



This symbol indicates recommendation.

1-3 PARTS IDENTIFICATION

Cover

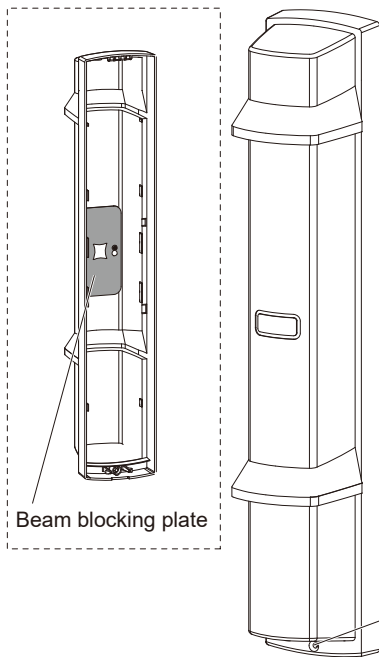

Main unit

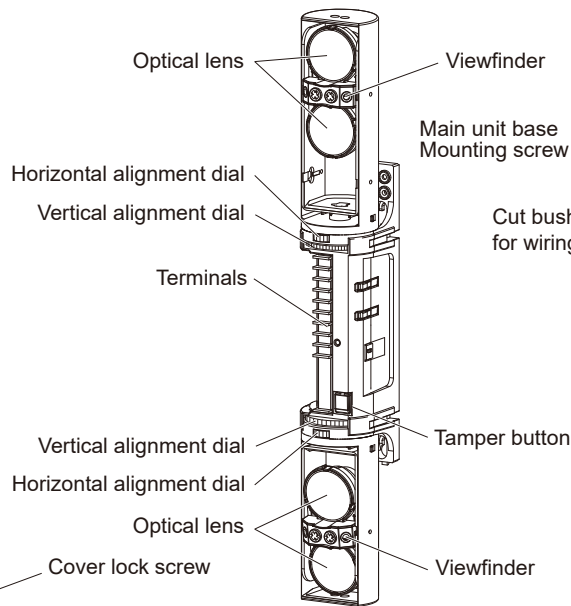

Chassis

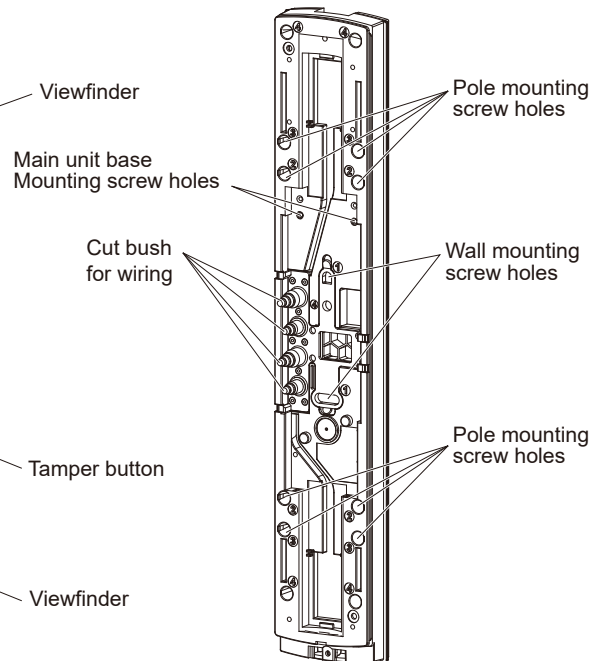

FUNCTION SETTING SECTION >>

<Transmitter>

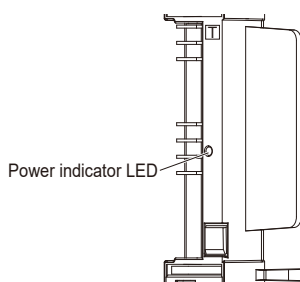

<Receiver>

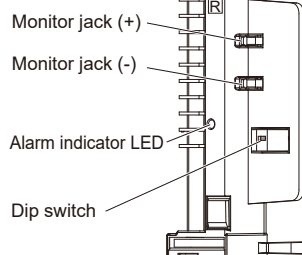

ACCESSORIES >>

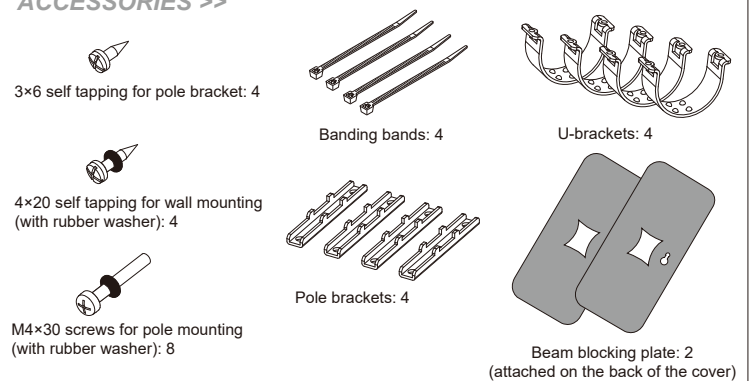

2 INSTALLATION

2-1 SEPARATING

1 Remove the cover.

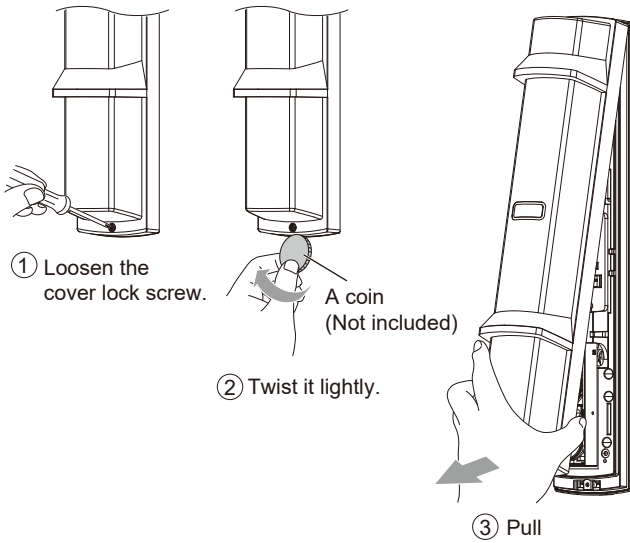

2 Remove the main unit from the chassis.

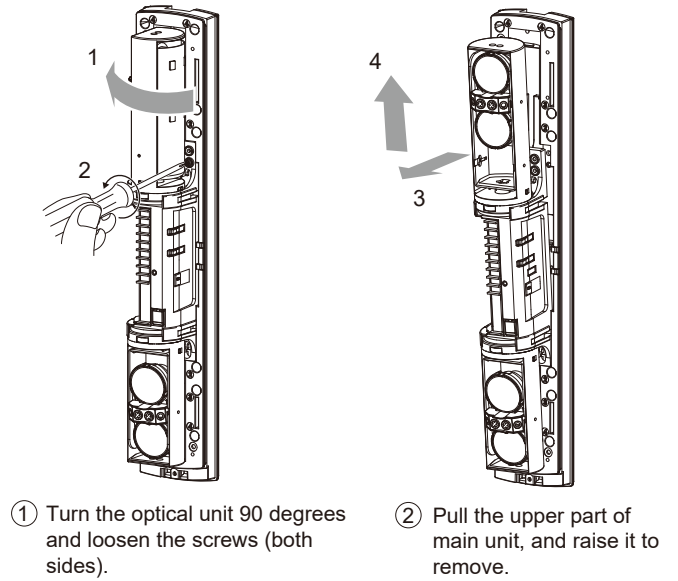

⚠ Caution

Do not place the main unit where it allows to incident direct sunlight to its optical lens during installation. Doing so may cause damage to the product.



2-2 WIRING

1 Preparing the cut bush

Cut the wiring grommet required according to the wire diameter. Use the lidded grommet for the wiring hole not to be used. (I.D. : Inter diameter)

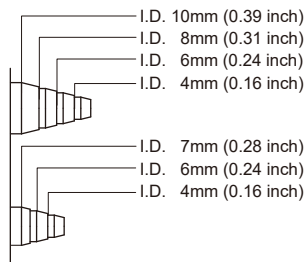

2 Threading the wire

- ① Cut off the cut bush according to the cable size. ② Pass the cable through the cut bush.

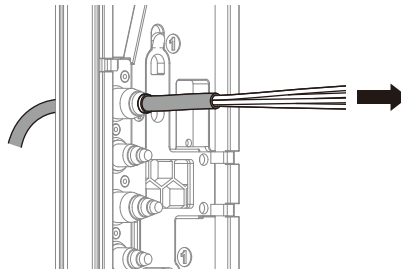
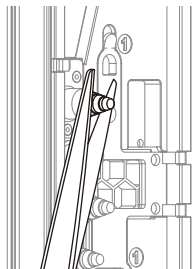

- ③ Tighten the cable with the banding band. ④ Cut the excess portion of the banding band. ⑤ Connect to the terminals

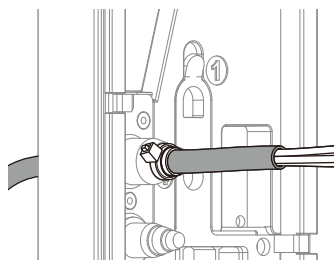
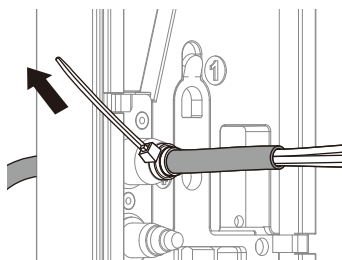

Refer to "TERMINAL" on Page 4 to make connections to the terminals and refer to "OPTICAL ALIGNMENT" on Page 8 to make alignment for the maximum level of light reception.

⚠ Caution

Do not exceed the voltage or current rating specified for any of the terminals during installation, doing so may cause fire or damage to the product.



2-3 TERMINAL

<Transmitter>

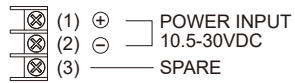

<Receiver>

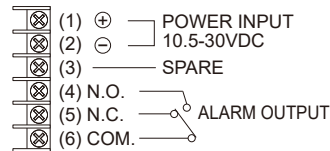

2-4 WIRING DIAGRAM

1 1 Set

Connect the power supplies in parallel.

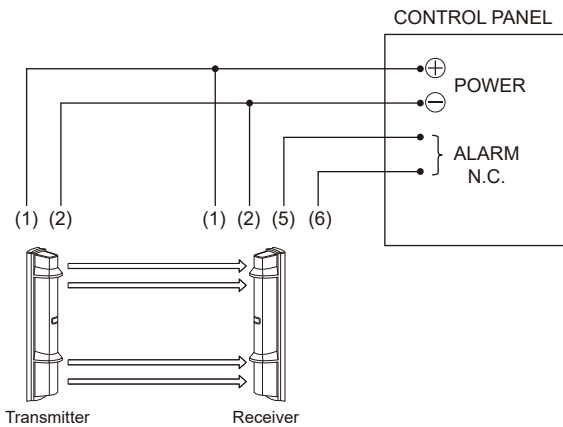

Note>>

2 Sets stacking installation is not available.

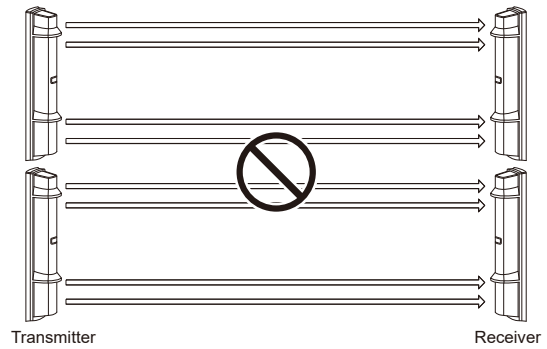

2 2 Sets in the line

Connect the power supply in parallel. Connect the units serially for a normally closed alarm output and in parallel for a normally open output (the figure below shows an example for a normally closed alarm output).

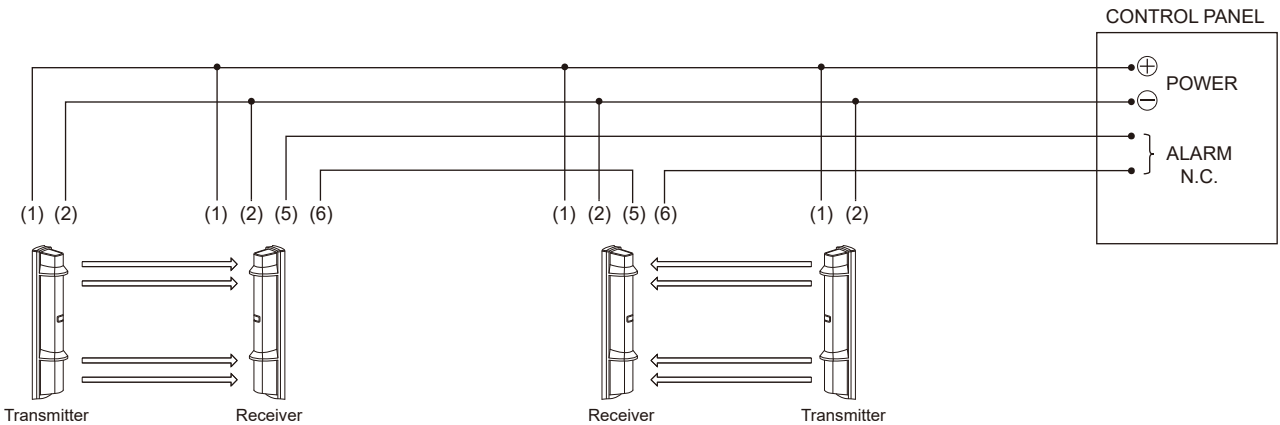

2-5 WIRING DISTANCE BETWEEN POWER SUPPLY AND DETECTOR

- Ensure that the wiring distance from the power supply is within the range shown in the table below.
- When using two or more units on one wire, the maximum length is obtained by dividing the wire length listed below by the number of units used.

MODEL	SL-200/350/650QN	
	12VDC	24VDC
0.33mm ² (AWG22)	400m (1300ft)	2300m (7300ft)
0.52mm ² (AWG20)	600m (2000ft)	3600m (12000ft)
0.83mm ² (AWG18)	1000m (3300ft)	5800m (19000ft)
1.31mm ² (AWG16)	1500m (5000ft)	9200m (30000ft)

Note>>

UL requires to be connected to a UL listed power supply capable of providing a nominal input of 12 VDC, (10.5 - 30 VDC) 40 mA and battery stand by time of 4 hours.

SL-200/350/650QN shall be installed in accordance with the National Electrical Code (NEC) 70 and CSA 22-2 Part1 of the Electrical Code for Canada.

2-6 WALL MOUNTING

- 1 Open the wiring guide on the back of the chassis using pliers as shown.

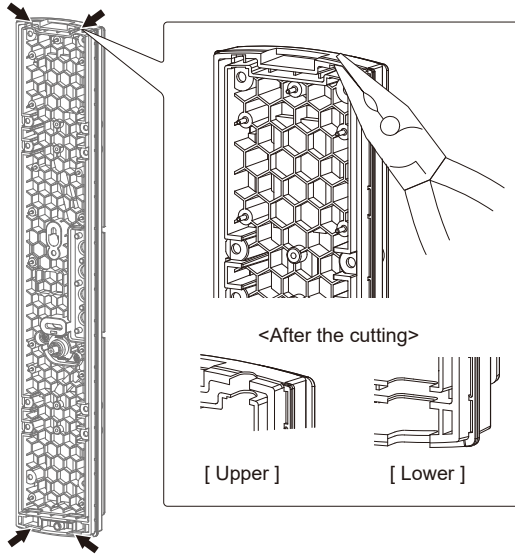

- 2 Pull the waterproof packing (x2) marked as "①" at the center of the chassis.

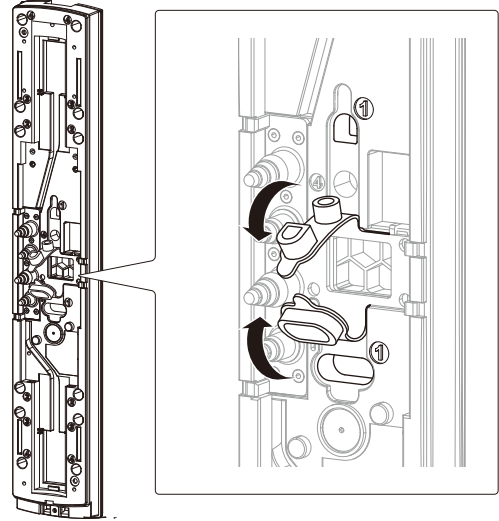

- 3 Mount the chassis to the wall.

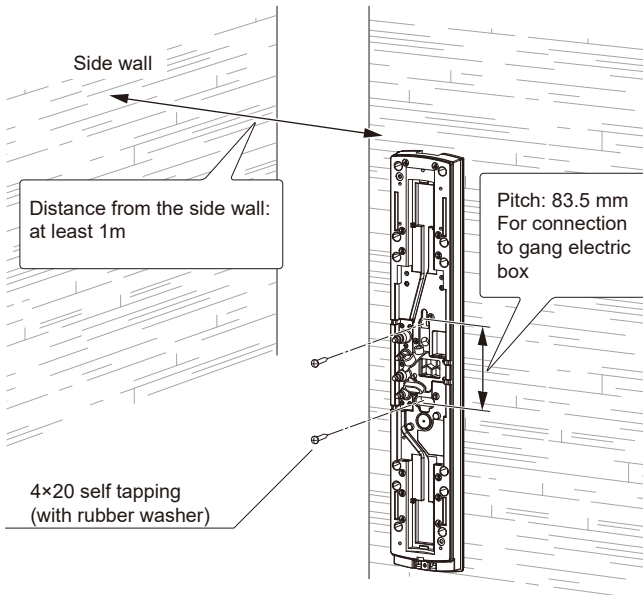

- 4 Put the waterproof packing back in place.

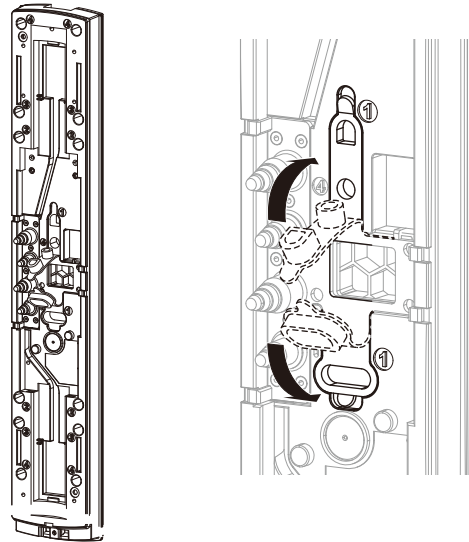

- 5 Fix the main unit.

- ① Insert the lower part, and then push the upper part onto the chassis.

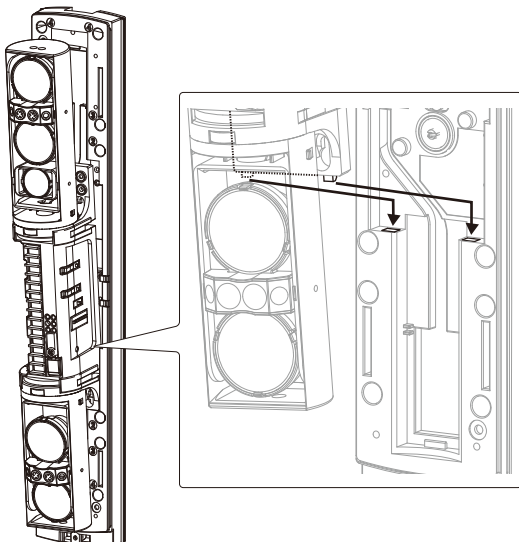

- ② Turn the optical unit 90 degrees and tighten the screws (both sides).

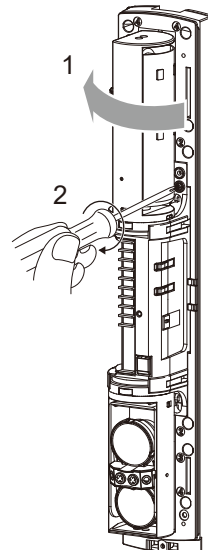

6 Mount the cover and check the operation.

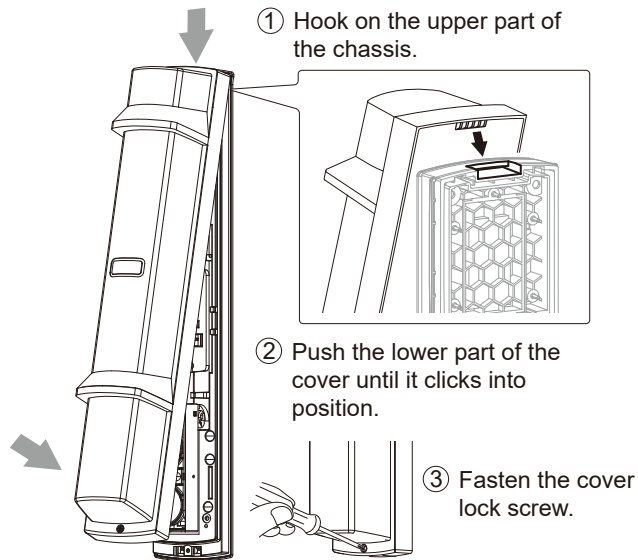

Note>>

Push the middle part of the cover and hide this orange label completely when in operation.

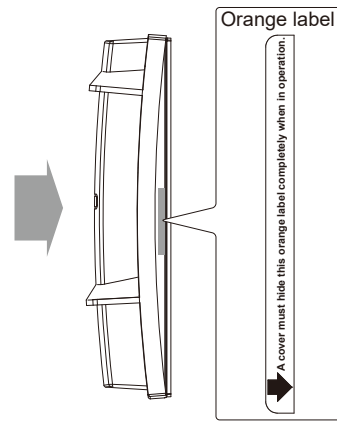

Make function settings and optical alignment before mounting the cover.

⚠ Caution

Do not contact with the optical unit when mounting the cover. Otherwise malfunction may occur due to the shift of the optical axis, resulting in the need of readjustment.



2-7 POLE MOUNTING

< Installing one detector >

1 Using a screwdriver or similar tool, break the knockout position (x4) in the chassis as shown.

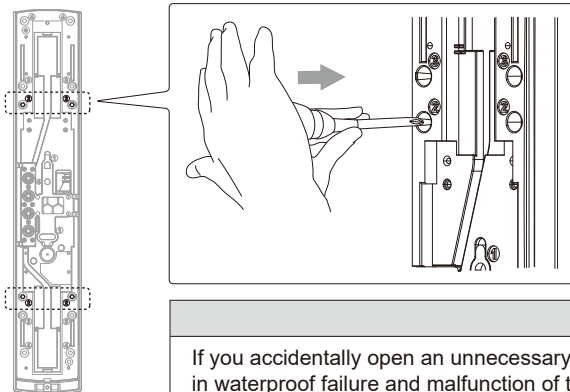

Note>>

- When mounting the single set of detectors to the pole, use a pair of the inside knockouts. The knockout positions are marked "②" as shown.

- Break the knockout from the direction shown (inside the chassis). Breaking from the opposite direction (outside of the chassis), makes a risk of generating burrs scratch the wire.

⚠ Caution

If you accidentally open an unnecessary knockout, be sure to fill the knockout. Not doing so may result in waterproof failure and malfunction of the product.



2 Fix the chassis on the pole.

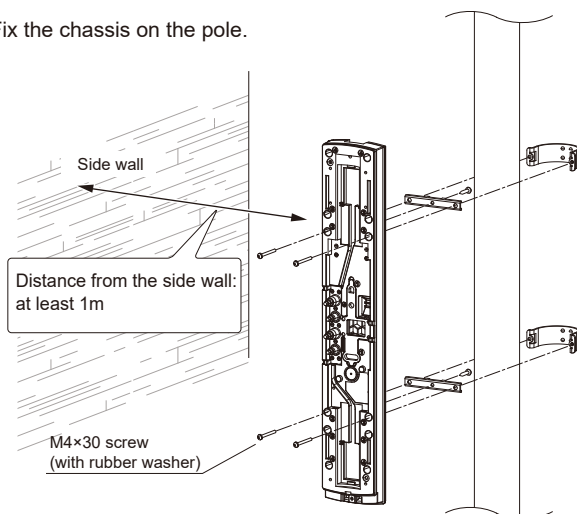

Note>>

- Before fixing the chassis on the pole, temporarily fix one point at the center of the pole mounting bracket to the back of the chassis.

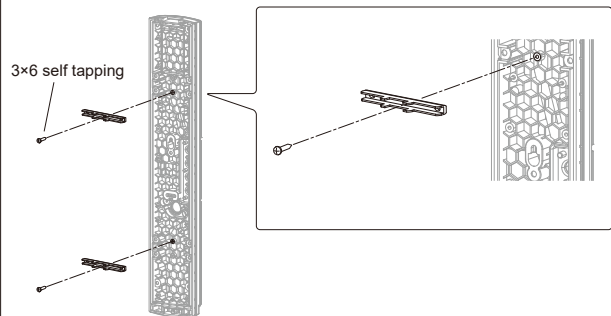

3 Perform the wall mounting procedure of **4** to **5** on page 5.



Make function settings and optical alignment before mounting the cover.

< Installing two detectors in opposing directions >

- Using a screwdriver or similar tool, break the knockout position (x4) in the chassis as shown.

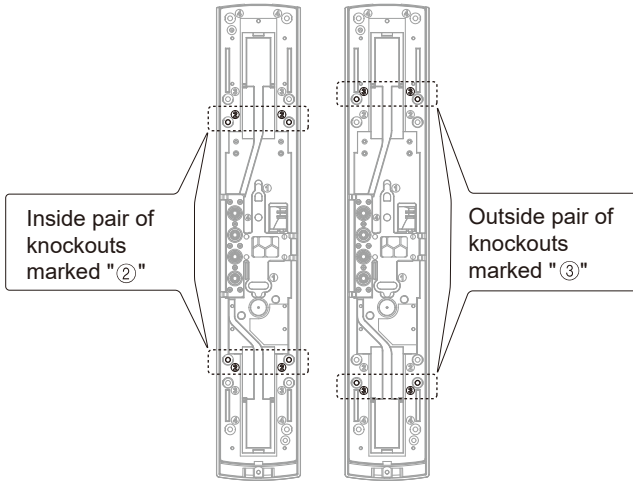

Note>>
 • Choose a different pair of knockouts.
 Pairs of the knockout positions are marked "2" and "3".

- Fix the chassis on the pole.

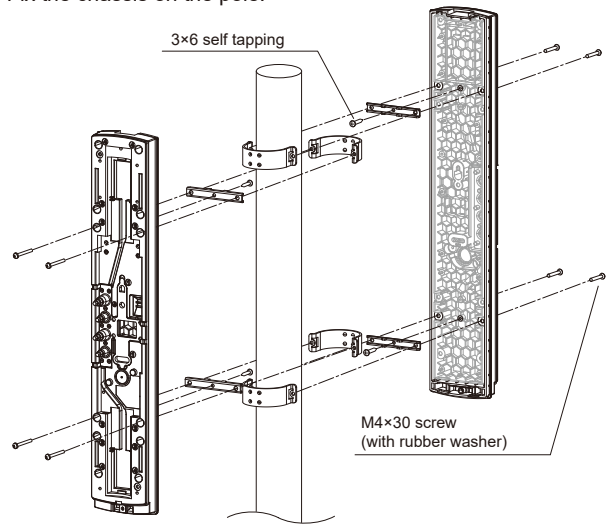

Note>>
 • Before fixing the chassis on the pole, temporarily fix one point at the center of the pole mounting bracket to the back of the chassis. Refer to procedure 2 of "Installing one detector".

- Perform the wall mounting procedure of 4 to 5 on page 5.

 Make function settings and optical alignment before mounting the cover.

2-8 MOUNTING IN THE BEAM TOWER

- In accordance with the type of the main unit inside the beam tower, install the detector in the same way as wall mounting or pole mounting.

< Mounting with the chassis > < Mounting without the chassis >

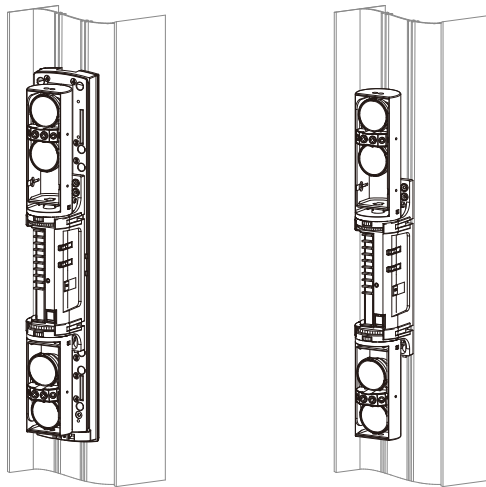

• Mounting in the Beam Tower without the cover / chassis not evaluated UL/ULC.

 Make function settings and optical alignment before mounting the cover.

2-9 INSTALLATION EXAMPLE AT PARTICULAR CASE

- Avoid installing the transmitter and receiver facing each other through the corner of the cover.

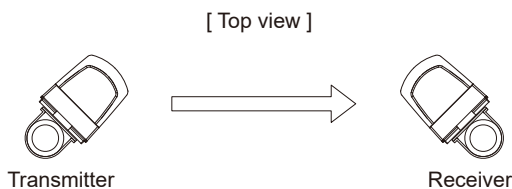

- In doing this installation, the maximum detection range shall be half of the original detection range. (This is to compensate the attenuation of beam by the corner of the cover.)

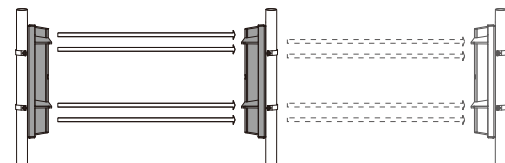





ex) SL-200QN 60m/200ft. → 30m/100ft.

3 FUNCTION SETTING

3-1 BEAM INTERRUPTION ADJUSTMENT

Initial setting is at 50 msec for normal work. According to the speed of a supposed target you select one specific setting out of 4 steps. Set the beam interruption adjustment switches of the Receiver according to the speed of the human object to detect.

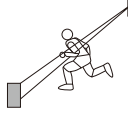
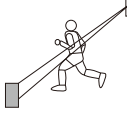
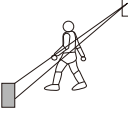
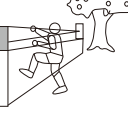
Dip switch (Receiver)	ON  1 2	ON  1 2	ON  1 2	ON  1 2
Typical interruption time setting	Running (50 msec)* 	Jogging (100 msec) 	Walking (250 msec) 	Slow movement (500 msec) 

* For UL/ULC Installations the Setting of 50 msec shall be used.

4 OPTICAL ALIGNMENT

4-1 OPTICAL ALIGNMENT FOR UPPER AND LOWER BEAM

Optical alignment is an important adjustment to increase reliability. Be sure to take adjustment steps 1 through 5 described below to attain the maximum level of the output through the monitor jack.

< Horizontal alignment angle >
[TOP VIEW]

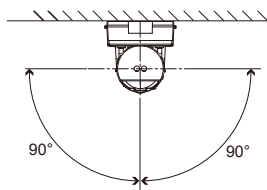

< Vertical alignment angle >
[SIDE VIEW]

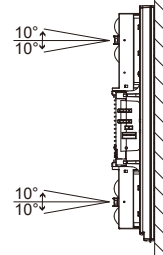

1 Perform rough alignment of the horizontal angle.

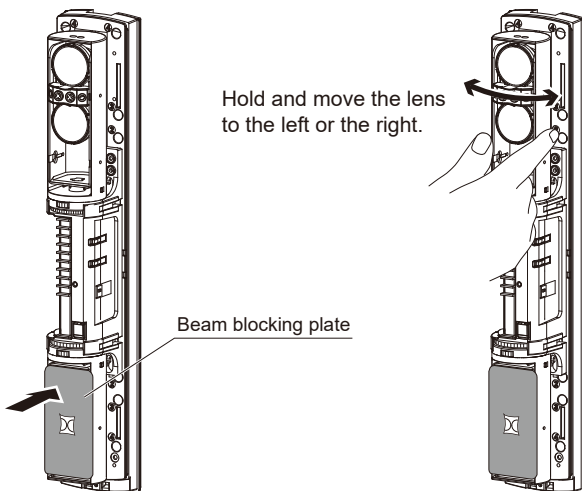

Note>>

- Mount a beam blocking plate to the lower unit and then start optical alignment from the upper unit.
- Beam blocking plate is attached on the back of the cover.
- Put back the beam blocking plate to the cover after use.

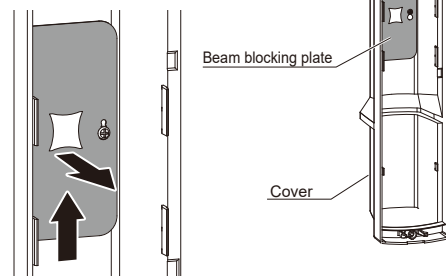

2 Look into the viewfinder and perform fine alignment of the horizontal and vertical angles using the alignment dial.

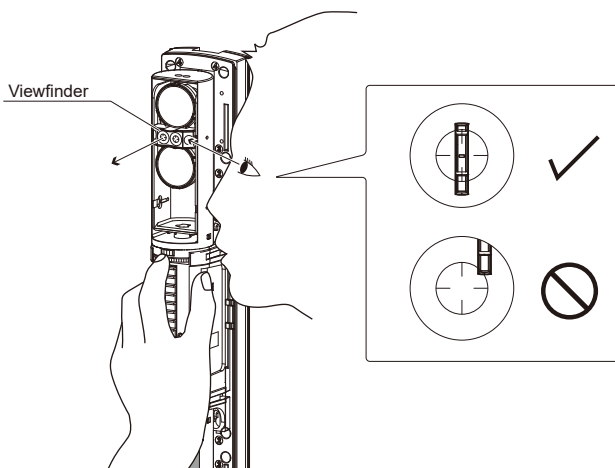

Note>>

< How to look into the viewfinder >

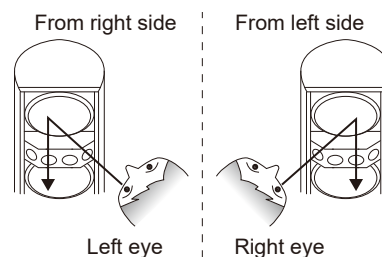

Note>>

Check the diagram below and perform fine alignment for both horizontal alignment and vertical alignment.

Turn the small dial for horizontal alignment.

Turn the large dial for vertical alignment.

- Clockwise: Upward
- Counterclockwise: Downward



Warning

Do not look at strong light sources such as sunlight through the viewfinder.



Caution

Do not touch the lens during optical alignment.



- 3** After the alignment using the viewfinder, make adjustment with the voltmeter for more accurate optical alignment. Set the voltmeter range to 5 to 10 VDC. After checking the receiving level of optical axis by using the alarm indicator, make sure to make fine alignment for both transmitter and receiver with voltmeter to achieve a monitor output level of "Excellent".

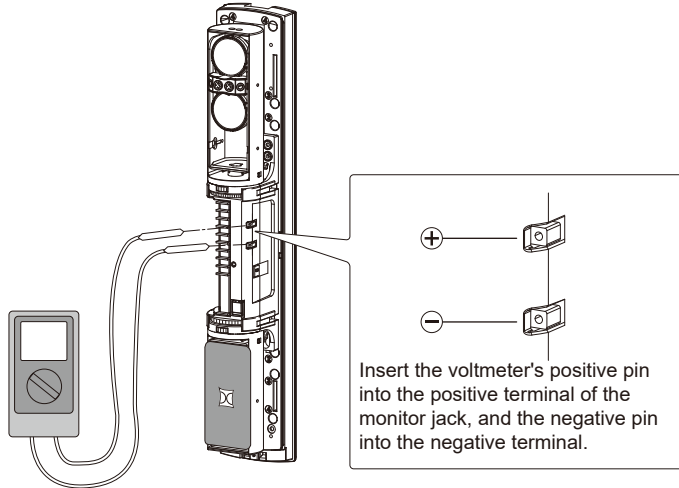

4

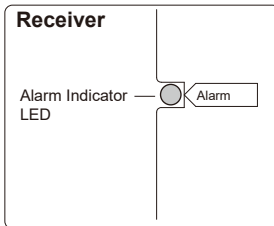

Receiver	Light interrupted	Light received			
	Alarm indicator LED	ON (Red)	OFF		
Adjustment level		Realign	Fair	Good	Excellent
Monitor jack output		0 V ▷	2.0 V ▷	3.5 V ▷	5.0 V ▷

Note>>

Power indicator LED on the transmitter is not turned off when the cover is closed. (i.e. The tamper button is depressed.)

Caution

Be sure to perform fine alignment to ensure the maximum output level through the monitor jack.



- 5** Make the settings of **1** to **4** to the lower as well.

5 OPERATION CHECK

Conduct a walk to check that the alarm indicator LED on the receiver turns ON as the walker interrupts the beam. Be sure to conduct a walk test (to block the infrared beam) at the following three points:

- A** In front of the transmitter
- B** In front of the receiver
- C** At the middle point between the transmitter and the receiver

Note>>

Conduct a walk test at least once a year.

The detector is installed properly when the Alarm indicator LED turns ON in the tests at all three points.

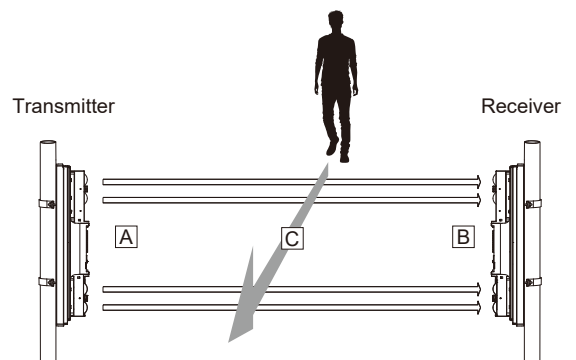

6 OPTION SETTING

6-1 HEATER UNIT HU-3 (OPTION)

The heat release effect makes the unit less prone to frost. HU-3 can be mounted to upper and lower part of the unit. Use a 24 V power supply to use HU-3.

< Mounting method >

- 1 Tear the wiring groove section of the label that is pasted on the chassis as shown below.

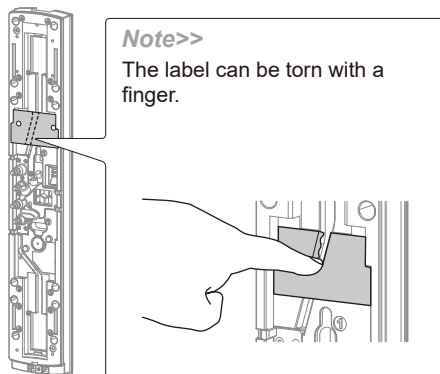

- 2 Insert HU-3 into the chassis.

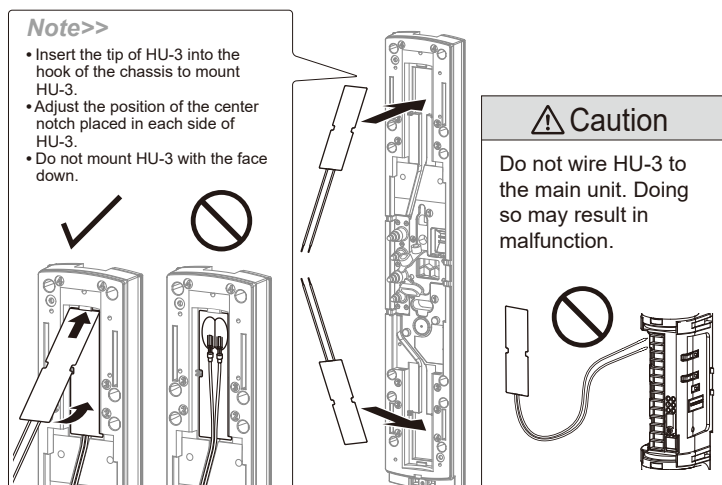

- 3 Route the cable along the wiring groove and draw the cable through the cutbush.

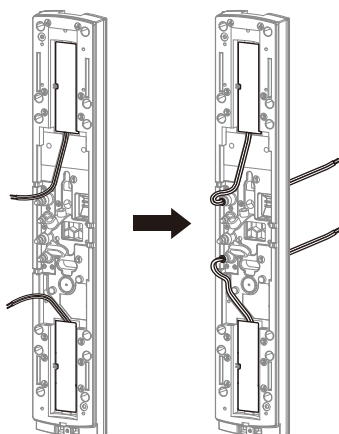

- 4 When connecting the lead wires to the wiring, make the connection using the included connector or soldering. Insert the wires into the connector and tighten the connections with pliers.

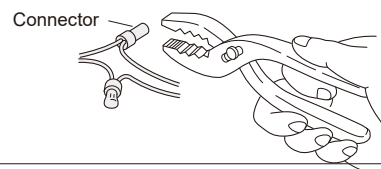

Note>>

Ensure that the wiring distance from the power supply is within the range shown in the table on the right. When using 2 or more units on 1 wire, the maximum wiring distance is obtained by dividing the wire distance by the number of unit used.

Wiring distance from power supply	
Wire size	Power supply: 24 VAC/DC
0.83 mm ² (AWG18)	300 m (1000 ft.)
1.31 mm ² (AWG16)	500 m (1700 ft.)
2.09 mm ² (AWG14)	800 m (2600 ft.)

HU-3 should be powered by the separate source than SL-200/350/650 QN.
UL requires to be connected to a UL listed power supply of providing a nominal input of 24 VAC/DC, 420 mA per 1 unit.
HU-3 shall be also installed in accordance with the National Electrical Code (NEC) 70 and CSA 22-2 Part 1 of the Electrical Code for Canada.

7 DIMENSIONS

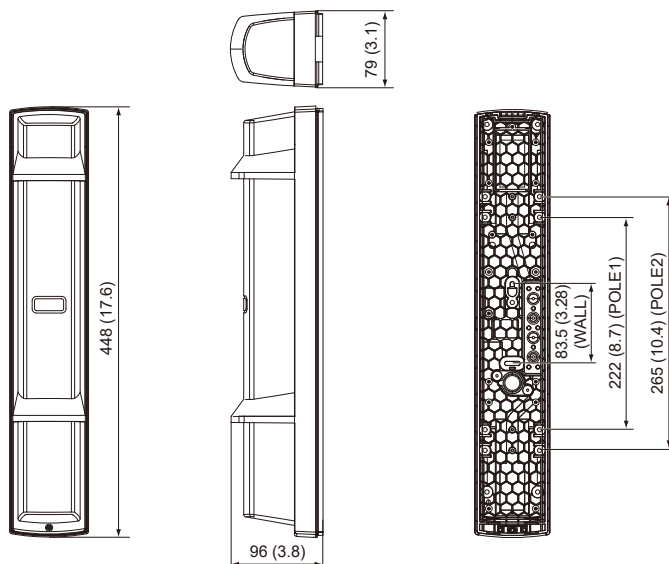

Unit: mm (inch)

8 TROUBLESHOOTING

PROBLEM	POSSIBLE CAUSE	CORRECTIVE ACTION
Indicator LED is not illuminated. (Transmitter : During normal operation) (Receiver : Beam interrupted)	Inappropriate power voltage	Check the voltage and make sure that it is between 10.5 and 30 VDC.
	Inappropriate wiring distance or wire diameter	See "2-5 WIRING DISTANCE BETWEEN POWER SUPPLY AND DETECTOR" on page 4, check the wiring distance.
"ALARM" indicator LED is not illuminated even if the beam is blocked.	Reflection of the floor or wall	See "4-1 OPTICAL ALIGNMENT" on Page 8 and make realignment.
	Beam has not been blocked.	Block all four beams at same time.
Blocking the beam, and illuminates "ALARM" indicator LED but does not active the alarm.	Signal line short-circuited	Check the wiring.
	Alarm contact welded	Repair is required. Contact the distributor or us.
Alarm is activated even if the light is not blocked.	Interruption time is too short.	See "3-1 BEAM INTERRUPTION ADJUSTMENT" on page 8, set an appropriate interruption time.
	Surface of Transmitter/Receiver cover soiled.	Clean the cover (wipe the cover with a soft cloth dampened with water od diluted neutral detergent).
	Optical alignment was not performed properly.	See "4-1 OPTICAL ALIGNMENT" on Page 8 and make realignment.
Frost, snow or heavy rain causes false alarm.	Optical alignment is not optimized.	See "4-1 OPTICAL ALIGNMENT" on Page 8 and make realignment.
Improper output	The wiring is incorrected.	Make correct wiring.

9 SPECIFICATIONS

< SL-200QN, SL-350QN, SL-650QN >

Model	SL-200QN	SL-350QN	SL-650QN
Maximum detection range	60 m/200ft	100 m/350 ft	200 m/650 ft
Maximum arrival distance	600 m/2000ft	1000 m/3500 ft	2000 m/6500 ft
Detection method	Quad infrared beam interruption detection		
Interruption time	Variable between 50/100/250/500 ms (4 steps)		
Power source	10.5 - 30 VDC		
Current draw	38 mA (Transmitter: 8 mA Receiver: 30 mA)	39 mA (Transmitter: 9 mA Receiver: 30 mA)	40 mA (Transmitter: 10 mA Receiver: 30 mA)
Output	Alarm output	Form C relay: 30 VDC, 0.2 A	
	Alarm period	2 sec (±1) (Nominal)	
	Tamper output	N.C. (contact output): 30 VDC, 0.1 A Opens when cover removed.	
Operating temperature	-25°C - +60°C (-13°F - 140°F)		
Operating humidity	95 % (max.)		
Alignment angle	±90° Horizontal, ±10° Vertical		
Dimension	H x W x D mm (inch): 448 (17.6) x 79 (3.1) x 96 (3.8)		
Weight	2400 g (84.7oz) (Total weight of Transmitter + Receiver, excluding accessories)		
International protection	IP65		

< HU-3 (Option) >

Model	HU-3
Power input	24VAC/DC
Current draw	210 mA max. per 1 piece / 420 mA max. per 1 unit
Thermo switch	60°C (140°F)
Operating temperature	-35°C - +60°C(-31°F - +140°F)
Weight	20g(0.7oz) (Heater(x2))
Packages	Heater(x2), Connector(x4), Waterproof agent

NOTE

These units are designed to detect an intruder and activate an alarm control panel. Being only a part of a complete system, we cannot accept responsibility for any damages or other consequences resulting from an intrusion.

Specifications and design are subject to change without prior notice.

Anti Bird Cap ABC-4

Prevent birds and small animals from the detector to reduce the false alarm.
Prevent streaming rain and snow from the front of the detector to keep the sensitivity.

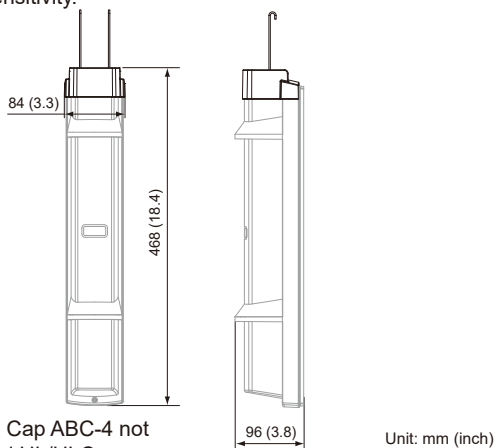

• Anti Bird Cap ABC-4 not evaluated UL/ULC.

Back Cover BC-4

Conceal the back side of pole mounted detector.

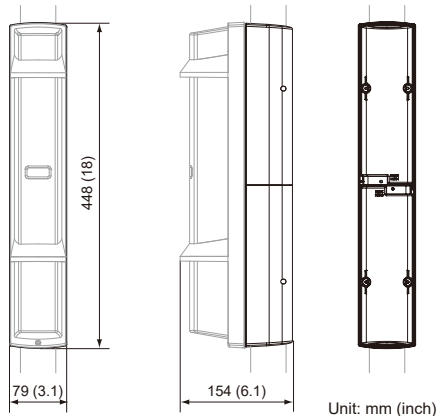

• Back Cover BC-4 not evaluated UL/ULC.

Conduit Bracket CBR-4

This allows for conduit wiring. (Compatible conduit: $\Phi 21$ mm (0.84 inch))

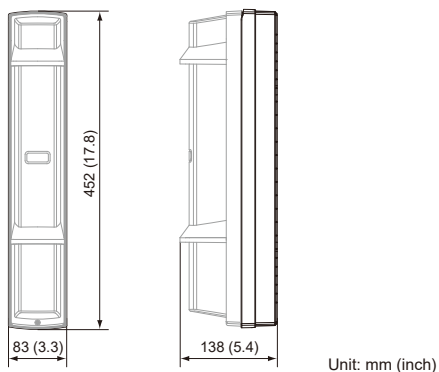

Pole Side Cover PSC-4

Conceal the gap of pole mounted detectors back to back.

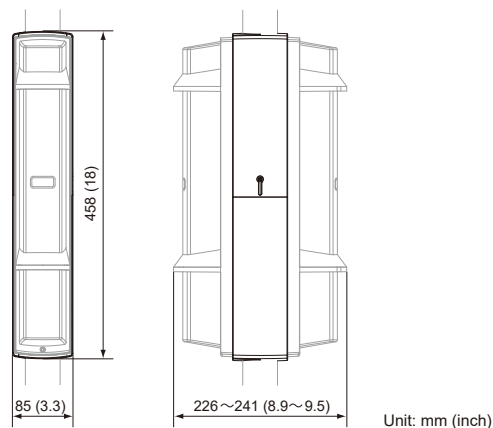

• Pole Side Cover PSC-4 not evaluated UL/ULC.

Beam Alignment Unit BAU-4

Adjust optical axis automatically. (Receiver only)

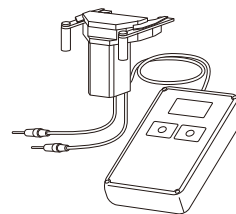

• Beam Alignment Unit BAU-4 not evaluated by UL/ULC.

Heater Unit HU-3

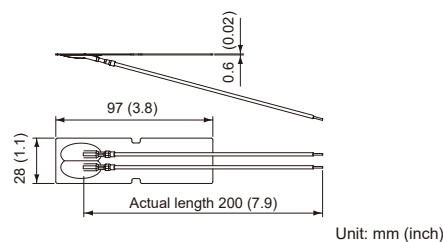

• Heater Unit HU-3 not evaluated by UL/ULC.

■ EU & UK contact information



<https://navi.optex.net/cert/contact/>



OPTEX INC./AMERICAS HQ (U.S.)
www.optexamerica.com

OPTEX (EUROPE) LTD./EMEA HQ (U.K.)
www.optex-europe.com

OPTEX SECURITY B.V.
(The Netherlands)
www.optex-europe.com/nl

OPTEX CO., LTD. (JAPAN)
www.optex.net

OPTEX SECURITY SAS (France)
www.optex-europe.com/fr

OPTEX SECURITY Sp.z o.o. (Poland)
www.optex-europe.com/pl

OPTEX PINNACLE INDIA,
PVT., LTD. (India)
www.optexpinnacle.com

OPTEX KOREA CO.,LTD. (Korea)
www.optexkorea.com

OPTEX (DONGGUAN) CO.,LTD.
SHANGHAI OFFICE (China)
www.optexchina.com

OPTEX (Thailand) CO., LTD. (Thailand)
www.optex.co.th

Copyright (C) 2014-2022 OPTEX CO.,LTD.