

MNT-ARM-V2

Wall Mount Bracket with IP66 Junction Box



- Aesthetic design
- Material: Aluminum
- Wall mount bracket with built-in IP66 junction box
- Fits medium sized dome cameras and PTZs with adaptors.

Technical Specification

Model	MNT-ARM-V2
Physical Properties	
Material	Aluminum
Color	White
Dimension(W xH xD)	5.28"x5.25"x7.38" (297mmx248mmx106mm)
Weight	1.54lb (0.7kg)
Load Bearing	8.82lb (4.0kg)
Operating Temperature	-40°F~140°F (40°C~60°C)
Humidity	0~90% RH
Inch Thread	G 3/4"
Included Hardware	Wall mount bracket with IP66 junction box (x1), ST4.2x25 screw (x4), Plastic Anchors (x4), S3.0 wrench (x1)
Applicable Models:	Fits medium dome cameras and PTZs with MNT-DVIR-V2, MNT-N23X4D-MPA102 or MNT-DVIR-MPA100 adapters.

Dimensions (mm/in)

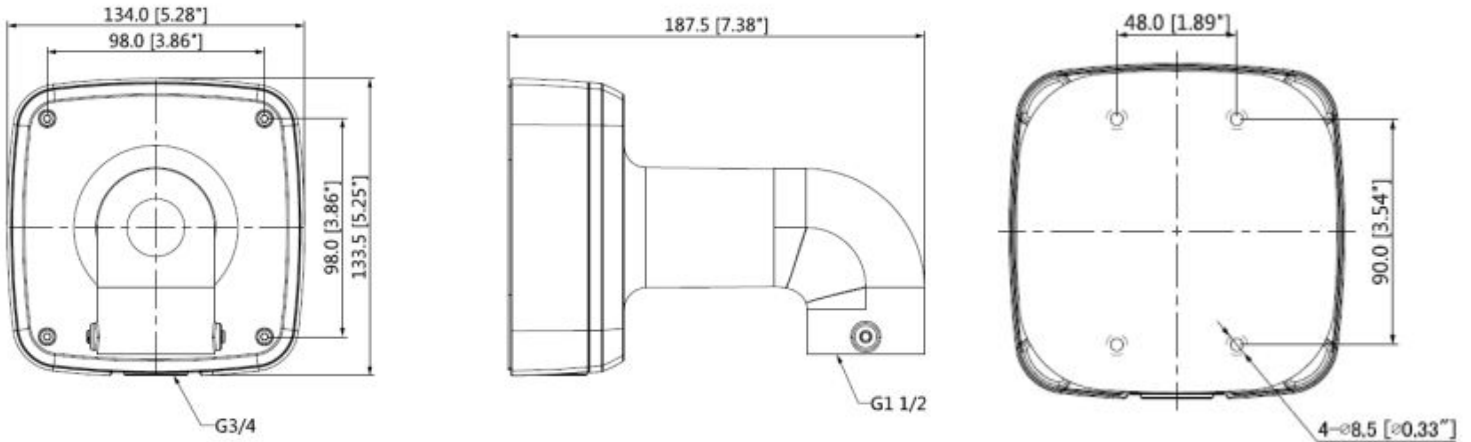

Application

