

# 600 Lb. Magnetic Gate Lock

DoorKing Part Number  
**DKGL-S6-1**

## Installation

It is essential that the surfaces of the armature and the magnetic lock seat perfectly to one another when the gate is in the closed position. This allows the lock to achieve its maximum holding strength. It is critical the armature is securely fastened to the gate frame or door, but able to move with the rubber spacer to correctly align with the magnetic lock.

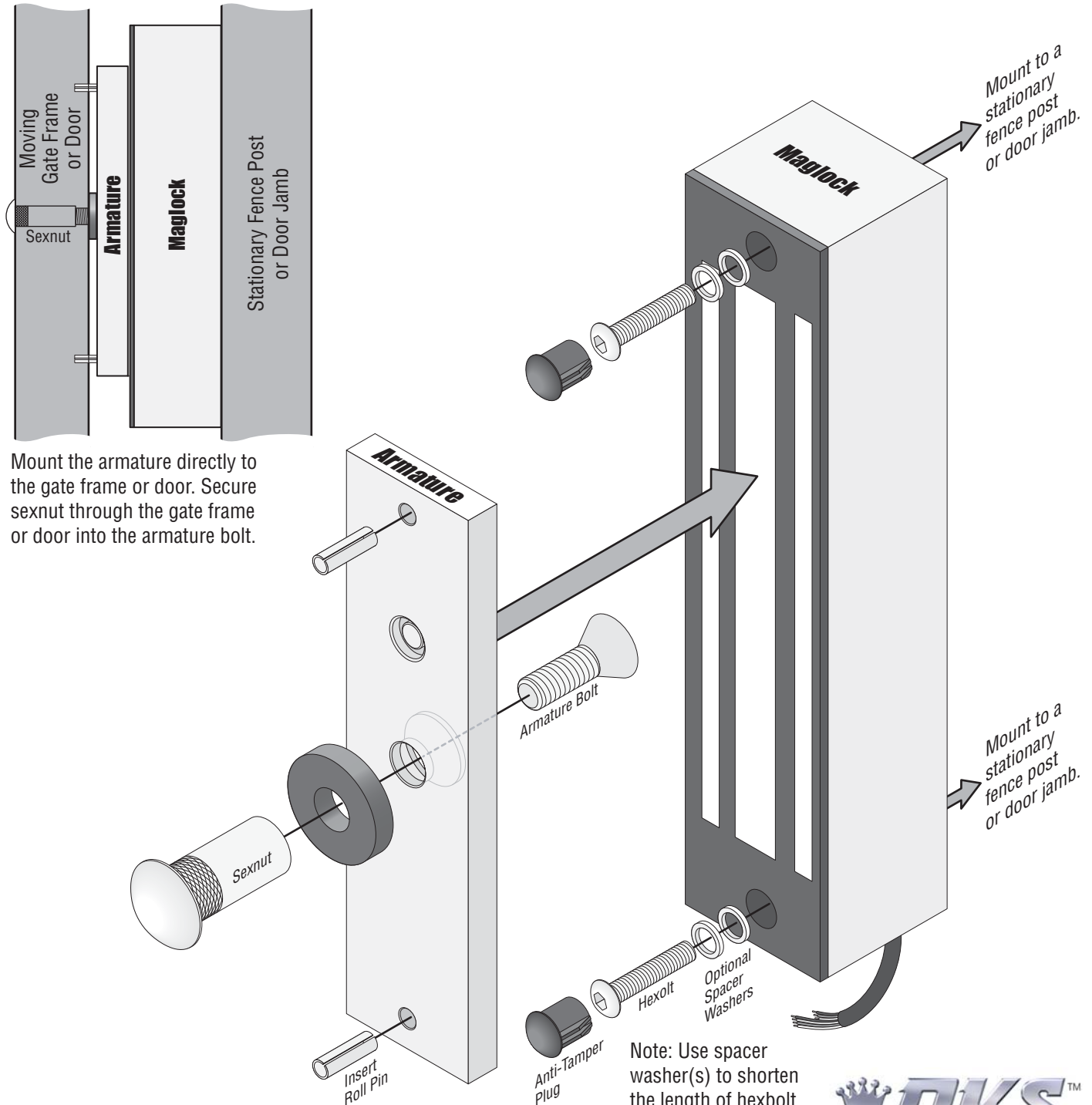

# Wire for 24 VDC or 12 VDC ONLY

DoorKing Part Number  
**DKGL-S6-1**

