

5883 Relay Interface Module

Product Installation Document

PN 151194:C 2/15/2022 ECN: 151062

1 Description

The 5883 is a Relay Interface Board with ten general purpose Form C relays which can be used for activating voice evacuation, elevator recall, or HVAC fan shutoff, as examples. Each relay is activated by an open collector input from a controlling device such as the 5880 LED Driver Module.

1.1 Compatibility

The 5883 is compatible with Honeywell Farenhyt and Silent Knight Series FACP's. For more information, refer to the *FACP Installation Manual*.

1.2 Specifications

- Operating Temperature: 32° - 120°F (0° - 49° C)
- Dimensions: 10.375" W x 10.25" H x 3.125" D
- Relay Trigger Voltage: 5VDC
- Form C Relay: 30VDC, 5A
- Operating Voltage: 24 VDC, 420 mA max (42 mA / relay)
- For indoor use only

2 Installation and Mounting



CAUTION: STATIC SENSITIVE COMPONENTS

THE CIRCUIT BOARD CONTAINS STATIC-SENSITIVE COMPONENTS. ALWAYS GROUND YOURSELF WITH A PROPER WRIST STRAP BEFORE HANDLING ANY BOARDS SO THAT STATIC CHARGES ARE REMOVED FROM THE BODY. USE STATIC SUPPRESSIVE PACKAGING TO PROTECT ELECTRONIC ASSEMBLIES.

1. Remove the two screws from the bottom of the 5883 and slide the board out. Store the board in a safe location.
2. Mount the 5883 cabinet using the four cabinet mounting keyholes.

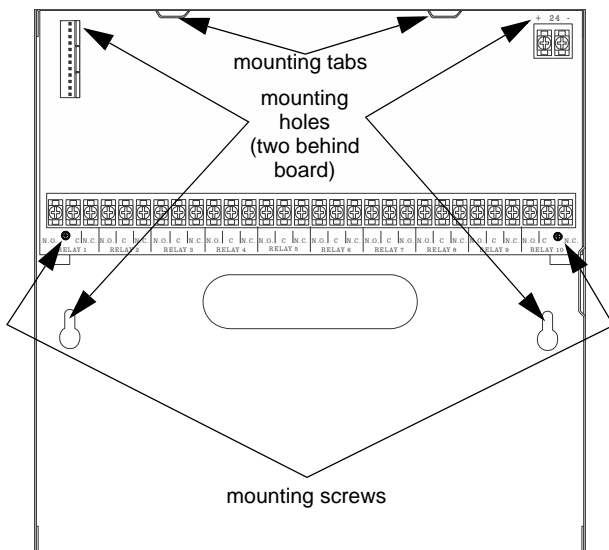

Figure 1 Mounting the 5883 Cabinet

3. When free of construction dust, slide the 5883 in between the mounting tabs at the top and secure to the studs in the back of the cabinet with the screws removed in step 1.

3 Wiring

All wiring is supervised and power-limited.



NOTE: Installation and wiring of this device must be done in accordance with NFPA 72 and local ordinances.

There are four available knockout for use when wiring the 5883, one on each side of the cabinet. Maintain 0.25" spacing between high and low voltage circuits and between power-limited and non-power-limited circuits. When using a combination of power-limited and non-power limited circuits, you must leave an unused relay in-between to maintain 0.25" spacing.

3.1 Connecting the 5883 to Aux Power

Connect the power terminals of the 5883 to a 24 VDC power supply as shown in Figure 2 below.

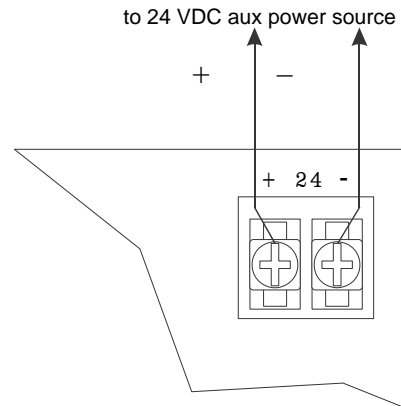

Figure 2 Auxiliary Power Connections



NOTE: Auxiliary power is supplied by a regulated, UL listed power supply for Fire Protective Signaling Systems.

3.2 Aux Power Using Flexput Circuits

The 5883 can use auxiliary power from any 24 VDC source. The following describes how to use Flexput circuits as the auxiliary power source.

1. Connect auxiliary power wiring to the Flexput terminals using "X" terminals as positive power and "O" terminals as negative power.

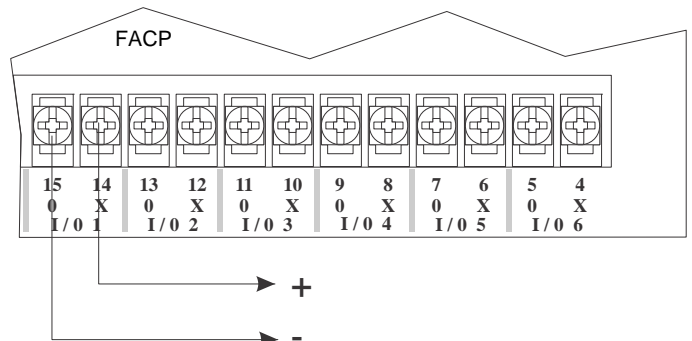
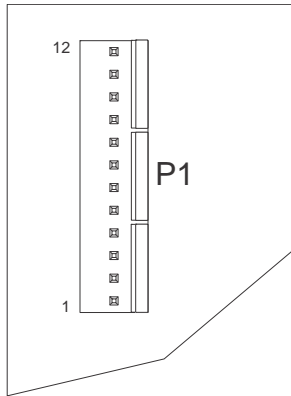

Figure 3 Flexput Auxiliary Power Output

2. Configure aux power output as constant output through FACP programming. For additional information, refer to the *FACP Instruction Manual*.

3.3 12-Pin Input Connector

The 5883 module's 12-pin input connector (P1) plugs directly into any of the 12-pin connectors on the 5880.



Must be wired within 3 feet of the 5883 and run in conduit.

Figure 4 12-Pin Input Connector

Table 1 lists the functions for connector P1 on the 5883.

Pin Number	Function	Pin Number	Function
1	Trigger Relay 1	7	Trigger Relay 7
2	Trigger Relay 2	8	Trigger Relay 8
3	Trigger Relay 3	9	Trigger Relay 9
4	Trigger Relay 4	10	Trigger Relay 10
5	Trigger Relay 5	11	+5 VDC
6	Trigger Relay 6	12	Not Used

Table 1 P1 Pin Functions

3.4 Relay Wiring

The ten onboard relays are Form C relays. Figure 5 shows an example of how the relays can be used.

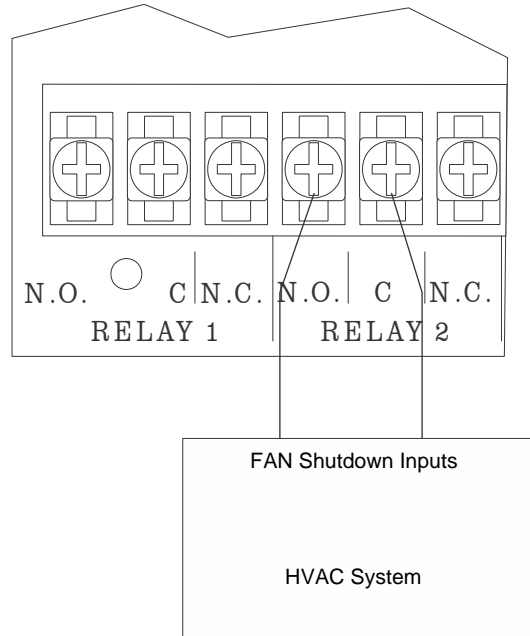

Figure 5 Relay Wiring Example