

mMINT—Modbus translator module— installation and use



Contents

Description	Page
List of figures	2
List of tables	2
Section 1: General description	2
Section 2: Features	3
Section 3: Installation	3
Module mounting.	3
Simplified wiring rules	3
Section 4: mMINT module connections	3
Power connections.	3
INCOM connections	4
Modbus connections	4
Section 5: Switches and indicator LEDs	4
Modbus RS-485 network Rx LED (green)	4
Modbus RS-485 network Tx LED (green)	4
INCOM network Rx LED (green)	4
INCOM network Tx LED (green)	4
Status LED (green).	4
INCOM 100 ohms termination DIP switch (SW1)	4
Modbus RS-485 baud rate DIP switch (SW2)	4
Unique mMINT address (SW2)	5
Modbus 121 ohm termination DIP switch (SW3)	5
Section 6: Network communication protocols	5
Overview	5
Function codes.	5
Block of registers.	5
Register access configurations	5
INCOM routing address configurations	6
Command/data pass-through.	6
Control of INCOM product.	6
Energy format	7
Supported diagnostic sub-functions.	8
Exception codes.	8
Section 7: Troubleshooting	9
Appendix A	9



Powering Business Worldwide

List of figures

Description	Page
Figure 1. The mMINT module	2
Figure 2. mMINT in a communications network.	2
Figure 3. Connections	3
Figure 4. Indicators	4
Figure 5. Switches.	4
Figure 6. Pass-through to INCOM product query data format	6
Figure 7. Pass-through to INCOM product response data format.	7
Figure 8. Control to INCOM product data format	7
Figure 9. 4-register energy data format	8

List of tables

Description	Page
Table 1. Power connector pin outs	3
Table 2. INCOM connector pin outs.	4
Table 3. Modbus RS-485 connector pin outs	4
Table 4. RS-485 baud rate switches (normal)	5
Table 5. RS-485 baud rate switches (diagnostics)	5
Table 6. Diagnostic sub-function numbers	8
Table 7. Troubleshooting guide	9
Table 8. Modbus register map (in register number order)	10
Table 9. Modbus register map (in functional order)	14
Table 10. Primary status code definitions.	17
Table 11. Secondary status code definitions.	17
Table 12. Cause-of-status code definitions.	17
Table 13. Control ‘Slave Action Number’ definitions	18
Table 14. mMINT configuration registers	19

Section 1: General description

The mMINT (Modbus® Master INCOM network translator) module, as seen in **Figure 1**, is an Eaton accessory product that will provide communication between a Modbus RTU network and an INCOM™ (INdustrial COMMunications) network (see **Figure 2**). This module is transparent to the Modbus network. It communicates to a master on the Modbus network using the Modbus RTU (remote terminal unit) protocol. It communicates to slave devices on the INCOM network using the PowerNet protocol. The catalog number of this product is MMINT.



Figure 1. The mMINT module

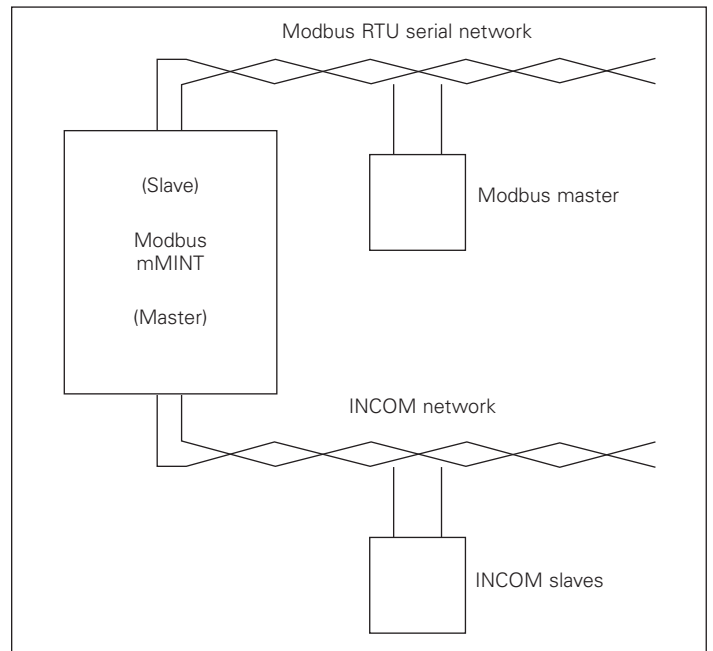

Figure 2. mMINT in a communications network

Section 2: Features

The mMINT module is a slave device on the Modbus network and as such requires a master that will exchange register objects with the mMINT module.

- Handles generic pass-through commands (Modbus/INCOM/Modbus)
- Capable of passing Modbus register objects from Eaton's existing products and newer Plug-n-Play products to a Modbus RTU master
- Data in IEEE® Floating Point format and fixed point.
- Modbus RTU communications data transfer rates of 1200, 9600, or 19200 baud with one start bit, eight data bits, no parity, and either one or two stop bits
- Up to 32 products connected to INCOM network port (246 unique addresses maximum)
- Flashing Status LED to indicate an active module
- LED indicators for INCOM transmit and receive communications exchanges
- LED indicators for Modbus RS-485 transmit and receive communications exchanges
- Input power for the module from either 120 Vac or 24 to 125 Vdc
- DIN rail mount package
- 0 °C to 60 °C ambient operation

Section 3: Installation

The mMINT module is designed to be installed, operated, and maintained by adequately trained personnel. These instructions do not cover all of the details or variations of the equipment for its storage, delivery, installation, checkout, safe operation, or maintenance.

⚠ WARNING

DO NOT ATTEMPT TO INSTALL OR PERFORM MAINTENANCE ON EQUIPMENT WHILE IT IS ENERGIZED. DEATH OR SEVERE PERSONAL INJURY CAN RESULT FROM CONTACT WITH ENERGIZED EQUIPMENT. ALWAYS VERIFY THAT NO VOLTAGE IS PRESENT BEFORE PROCEEDING. ALWAYS FOLLOW SAFETY PROCEDURES. EATON IS NOT LIABLE FOR THE MISAPPLICATION OR MISINSTALLATION OF ITS PRODUCTS.

If you have any questions or need further information or instructions, please contact your local Eaton representative or the Customer Support Center at 877-ETN-CARE (877-386-2273).

Module mounting

When mounting the mMINT, verify that an **11H x 28W mm DIN rail** is used and that it is within an enclosed space.

Simplified wiring rules

INCOM network

The following simplified rules apply to a given system consisting of a single daisy-chained main cable link between master and slave devices (see **Figure 2**). For more complex considerations, including star configurations, please refer to the wiring specification T.D. 17513.

- Recommended INCOM cable styles are Belden 9463 or C-H style 2A957805G01
- The maximum system capacity is 10,000 feet of communications cable and 32 slave devices on the INCOM network under the mMINT
- Non-terminated taps, up to 200 feet in length, off the main link are permitted, but add to the total cable length

- Make sure that there is twisted-pair wire that is recommended for PowerNet network use. Use shielded twisted-pair wire to connect each slave to the INCOM network, daisy-chain style. **The polarity of the twisted pair is not important.**

Modbus RS-485 network

The following simplified rules apply to a given system consisting of a cable link between master and slave devices (see **Figure 2**). For more complex configurations, please refer to standard Modbus RTU wiring specification rules for the RS-485 network.

- The recommended Modbus cable has twisted-pair wires (24 AWG stranded 7x32 conductors with PVC insulation) having an aluminum/mylar foil shield with drain wire
- The maximum system capacity is 4000 feet of communications cable and 247 devices on the Modbus RTU network
- Make sure that there is twisted-pair wire that is recommended for Modbus RTU network use. Use shielded twisted-pair wire to connect each slave to the Modbus RTU network, daisy-chain style. **The polarity of the twisted pair is critically important.**

Section 4: mMINT module connections

Refer to **Figure 3** and the following three pin out tables for installation specifics.

Power connections

Power connector: Module power uses a 5-pin input connector (see **Figure 3**). Power requirements are 120 Vac, 60 Hz or 24–125 Vdc. Refer to **Table 1**.

Table 1. Power connector pin outs

Pin number	Input power
1	Chassis ground
2 and 3	Vac neutral/Vdc common
4 and 5	Vac line/24–125 Vdc+

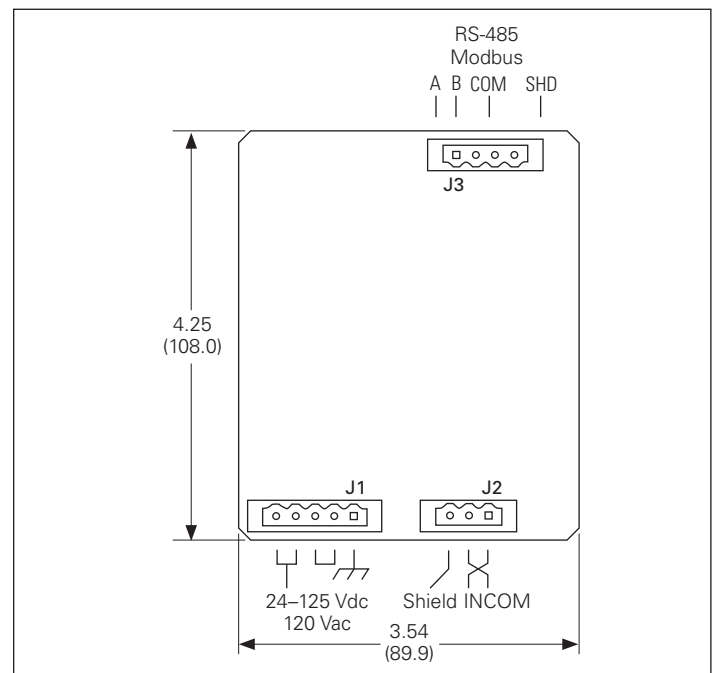

Figure 3. Connections

INCOM connections

INCOM connector: This 3-pin connector provides the interface to the INCOM network. Refer to **Table 2**.

Table 2. INCOM connector pin outs

Pin number	Input/output signal
1	INCOM carrier network
2	INCOM carrier network
3	Shield

Connect shield wire to ground at master device end only. Interconnect shielding where devices are daisy chained.

Modbus connections

Modbus RS-485 Connector: This 4-pin connector provides the interface to the Modbus RTU network. The polarity is “critically” important. Refer to **Table 3**.

Table 3. Modbus RS-485 connector pin outs

Pin number	Input/output signal
1	RS-485 Network-A (non-inverting)
2	RS-485 Network-B (inverting)
3	Common
4	Shield

RS-485 Network-A is the non-inverting differential connection for the Modbus RTU network. RS-485 Network-B is the inverting differential connection for the Modbus RTU network.

Section 5: Switches and indicator LEDs

Refer to **Figure 4** to locate the Status LED for the mMINT module. **Figure 5** shows the location of the configuration switches.

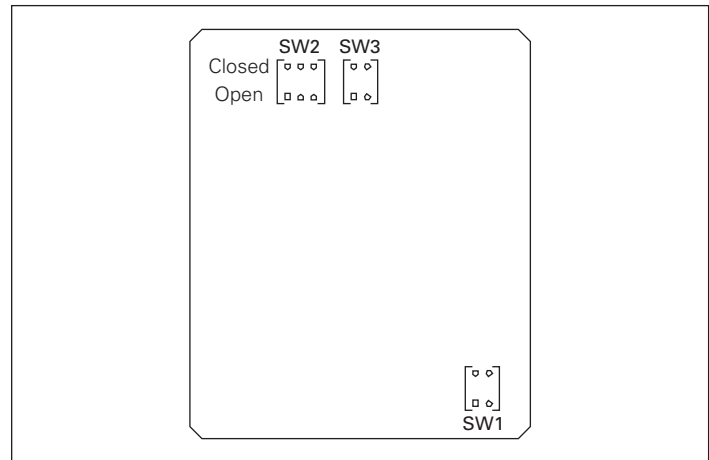

Figure 5. Switches

Modbus RS-485 network Rx LED (green)

The LED will be lighted whenever the module is receiving from the Modbus RTU network.

Modbus RS-485 network Tx LED (green)

The LED will be lighted whenever the module is transmitting on the Modbus RTU network.

INCOM network Rx LED (green)

The LED will be lighted whenever the module is receiving from the INCOM network.

INCOM network Tx LED (green)

The LED will be lighted whenever the module is transmitting on the INCOM network.

Status LED (green)

This indicator will be flashing whenever the module is powered up and the microcontroller is executing instructions. The flashing rate is approximately 1 second ON / 1 second OFF. However, detection of a communications error on either the Modbus or INCOM network will result in an increased flashing rate approximately 1/2 second ON / 1/2 second OFF. The rate will return to normal when the network’s diagnostic reset subfunction (clear UART or slave counters, respectively) is processed by the mMINT. See Section 6 and **Table 6**.

INCOM 100 ohms termination DIP switch (SW1)

This switch should be moved to the ON position only when it is the last unit in a chain of units or if it is a single unit.

Modbus RS-485 baud rate DIP switch (SW2)

To configure the data transfer rate for the Modbus RTU network, three switches in DIP switch SW2 should be moved to either the CLOSE or the OPEN position based on the rate required. Refer to **Table 4**. SW2-1 is for mMINT diagnostics.



Figure 4. Indicators

Table 4. RS-485 baud rate switches (normal)

Baud	SW2-1	SW2-2	SW2-3
1200	X	CLOSE	CLOSE
9600	X	OPEN	CLOSE
19200	X	CLOSE	OPEN

Unique mMINT address (SW2)

The mMINT can be assigned address 247 and 248. For the mMINT to respond to a diagnostic query related to address 247 or 248 on the Modbus network, move DIP switch SW2-1 to the OPEN position. Refer to **Table 5**. Normally, this switch is in the CLOSE position.

Table 5. RS-485 baud rate switches (diagnostics)

Baud	SW2-1	SW2-2	SW2-3
Addr. 247 or 248	OPEN	X	X
Normal	CLOSE	X	X

Modbus 121 ohm termination DIP switch (SW3)

This switch should be moved to the ON position only when it is the last unit in a chain of units or if it is a single unit.

Section 6: Network communication protocols

The lower INCOM communication network for the mMINT is based on a master-slave protocol. The mMINT is a master on the INCOM network.

In order to satisfy the mMINT communications needs, please see Reference Materials:

IL17384—Part A: INCOM Communications Standard, Eaton. Specific product profiles are located in the other Part sections. <http://www.eaton.com>, then search on 17384.

“Modicon Modbus Protocol”
<http://www.modicon.com/techpubs/toc7.html>

Overview

The contents of Modbus registers are INCOM product objects (e.g., I_A —phase A current). The mMINT ensures that unique objects reside in identical registers independent of INCOM product. Consequently, for all INCOM products there is a single register map of objects. See **Table 8** or **Table 9**.

INCOM objects occupy two registers except for certain energy—real and reactive—objects. These energy objects occupy four registers. The mMINT can support a maximum of 122 registers within a single Modbus transaction.

The mMINT is transparent to the Modbus master and responds to every address of INCOM products attached to it. In its default configured state, INCOM product addresses are Modbus network addresses. The mMINT can be configured to route the Modbus address to a different INCOM product address or an INCOM sub-network product address. See Section 6.

An upgrade has been incorporated to allow the mMINT to communicate with Modbus masters that can only access to register 9999. Registers previously assigned above 9999 have been assigned dual access, both at the original register (to provide compatibility) and at a new register assignment below 9999.

The format is given as low/high register numbers followed by (low₁₆/high₁₆ Modbus register addresses), for example: 4xxx/4yyyy (XXXX+1₁₆/YYYY+1₁₆). See **Table 14**.

Only the RTU communications mode is recognized by the mMINT.

Function codes

The mMINT responds to a limited number of Modbus function codes. These are function codes 03, 04, 08, and 16 (10₁₆).

Block of registers

A block of registers (from the register column of **Table 8** or **Table 9**) can be established for each INCOM product attached to a mMINT.

Function code 16 (10₁₆) is used to load the object assignments for the block of registers. The block assignments are stored beginning at register 41001/420481 (03E8₁₆/5000₁₆). Only the first object register address is assigned within the block of registers. For example, although object I_A occupies registers 404611 (1202₁₆) and 404612 (1203₁₆), only register address (1202₁₆) is loaded into the block of assignment registers. Verification of this block of assignment registers can be read from the mMINT by a read function code 03 or 04 from these 41001/420481 (03E8₁₆/5000₁₆) registers.

Data pertaining to the objects configured in the block of assignment registers is mapped into registers starting at 41201/420737 (04B0₁₆/5100₁₆) and continuing in successive order for each object assigned. The number of objects and their placement order in this data block of registers is dependent on the configuration of the block of assignment registers. The total number of data block of registers is limited to 100.

Note: An object can occupy one, two, or four registers.

The data can be obtained from the data block of registers by a read function code 03 or 04. The address of the starting object must be aligned with a starting address of an object within the data block of registers. The number of registers to obtain must align with an ending address of an object within the data block of registers.

Register access configurations

Non-volatile register 42001/425345 (07D0₁₆/6300₁₆) is used to configure the mMINT to respond to a group of data objects, of which some objects are invalid within that group. When non-zero (factory default value), any attempt to access a group of data objects that contain an invalid object will result in an illegal data object exception code 02. See Section 6.

When register 42001/425345 (07D0₁₆/6300₁₆) is set to zero, however, the mMINT will respond to a group of objects with data contained in the valid objects of the group along with an illegal value, if available else 0000₁₆, data contained in the invalid objects.

Non-volatile register 42002/425346 (07D1₁₆/6301₁₆) is used to configure 32-bit IEEE floating point word order. When non-zero (factory default), the floating point low order word is first in the Modbus register space.

When register 42002/425346 (07D1₁₆/6301₁₆) is set to zero, however, the floating point high order word is first in the Modbus register space.

Non-volatile register 42002/425347 (07D1₁₆/6302₁₆) is used to configure 32-bit fixed point and 64-bit energy word order. When non-zero (factory default), the fixed point and energy low order word is first in the Modbus register space.

When register 42003/425347 (07D2₁₆/6302₁₆) is set to zero, however, the fixed point and energy high order word is first in the Modbus register space.

Registers not containing a 32-bit or 64-bit format, such as Status and Product ID objects, pass through registers, INCOM control registers, and INCOM routing address configuration registers, are not effected by the word order configuration registers.

Configuring any or all registers 42001/425345 through 42003/425347 (07D0₁₆/6300₁₆ through 07D2₁₆/6302₁₆) is accomplished using a write function code 16 (10₁₆) to mMINT diagnostic address 247 or 248.

Note: mMINT SW2-1 must be properly set. See Section 5 and **Table 5**.

INCOM routing address configurations

Non-volatile registers 42101 (0834₁₆) through 42592 (0A1F₁₆) are used to configure the 246 Modbus-to-INCOM Routing Address registers. Two consecutive INCOM routing registers correspond to each Modbus address. The first register provides routing to an INCOM main network address while the second (first+1) register provides routing to an INCOM sub-network address. Registers 42101 and 42102 correspond to Modbus address 1, registers 42103 and 42104 correspond to Modbus address 2, etc.

Valid INCOM addresses range from 0001₁₆ through 0FFF₁₆. Invalid INCOM addresses are 0000₁₆ or Yxxx₁₆, where Y is non-zero. Any invalid (default) setting in the INCOM main network address register will cause the mMINT to access the INCOM product with the Modbus network address. A valid INCOM main network address register with an invalid INCOM sub-network address register will route the Modbus network address to the INCOM product at the configured main network address. Both a valid INCOM main network address register and INCOM sub-network address register will route the Modbus network address to an INCOM product at the configured sub-network address accessed through a sub-network master addressed at the INCOM main network address.

All INCOM Routing Address Configuration registers can be reset to their default state using the Diagnostics function code 08, sub-function 30 (1E₁₆). See Section 6 and **Table 6**.

Command/data pass-through

A feature of the mMINT is its capability to pass INCOM commands/data directly through to any of 32 attached INCOM products. Thus, with access to IL 17384, Parts A through F, every INCOM product object and capability is available to the Modbus master.

When passing a command or data through to an INCOM product, the mMINT acts as a dumb slave. Without modification, it passes the command or data through to the INCOM product.

In the event the product responds, the mMINT saves the response until the Modbus master queries for that response. The response data remains in the mMINT until another pass-through command is issued to an attached product or a mMINT power cycle occurs. The mMINT makes no modification to or interpretation of the product response data.

The Modbus master writes the INCOM product command/data using function code 16 (10₁₆) beginning at register 42601/424577 (0A28₁₆/6000₁₆).

The data format for passing information through the mMINT to an INCOM product is given in **Figure 8**.

The Modbus master reads the INCOM product response to a pass-through query using either function code 03 or 04 beginning at register 42701/424833 (0A8C₁₆/6100₁₆).

The number of points (registers) of the read query is 2*nn—where nn is the number of INCOM messages in the response.

The format of the data acquired by the mMINT from the pass-through INCOM product query's response is given in **Figure 7**.

Note: Each INCOM response message contains a status byte that indicates its validity.

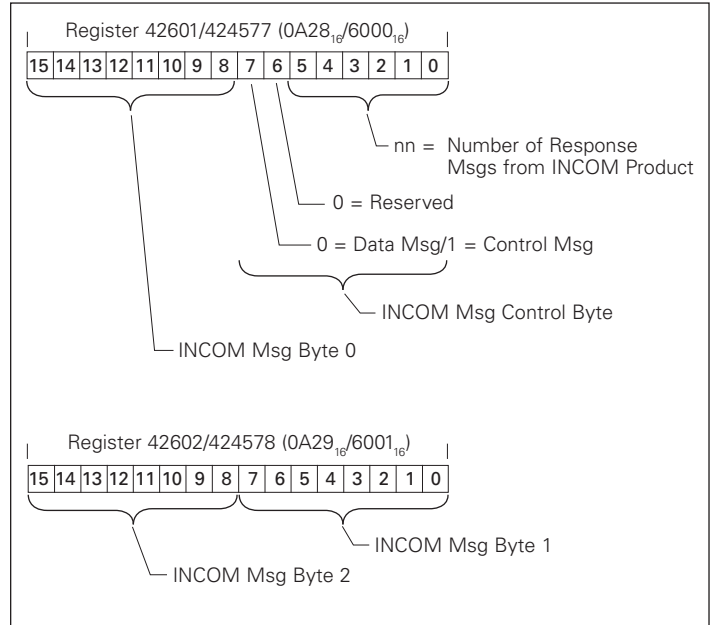

Figure 6. Pass-through to INCOM product query data format

Control of INCOM product

Since a control error could result in unwanted actions initiated by an INCOM device, the mMINT requires a specific protocol by the Modbus master in order to perform control related functions within the INCOM product.

A set of registers is reserved for the control protocol. They begin at register 42901/425089 (0B54₁₆/6200₁₆) and extend through 42903/425091 (0B56₁₆/6202₁₆). These three registers are written with a 'slave action number' and its 1's complement using function code 16 (10₁₆). The current 'slave action numbers', their support being product dependent, are listed in **Table 13**. The format of the data is shown in **Figure 8**. These three registers, and only these three registers, must be written in one Modbus transaction.

If the 'slave action number' and its 1's complement are valid, the mMINT issues the 'slave action' control command onto the INCOM network. If the slave action request is successfully acknowledged by the INCOM product, the mMINT returns a normal function code 16 (10₁₆) response to the Modbus master. The Modbus master may further determine if the INCOM product completed the slave action function successfully by interrogating the product, for example, by reading its status.

If the INCOM product does not acknowledge the slave action request, the mMINT returns an exception code 04. If the 'slave action number' and its 1's complement are invalid, the mMINT responds to the Modbus master with a data value illegal exception code 03. See Section 6.

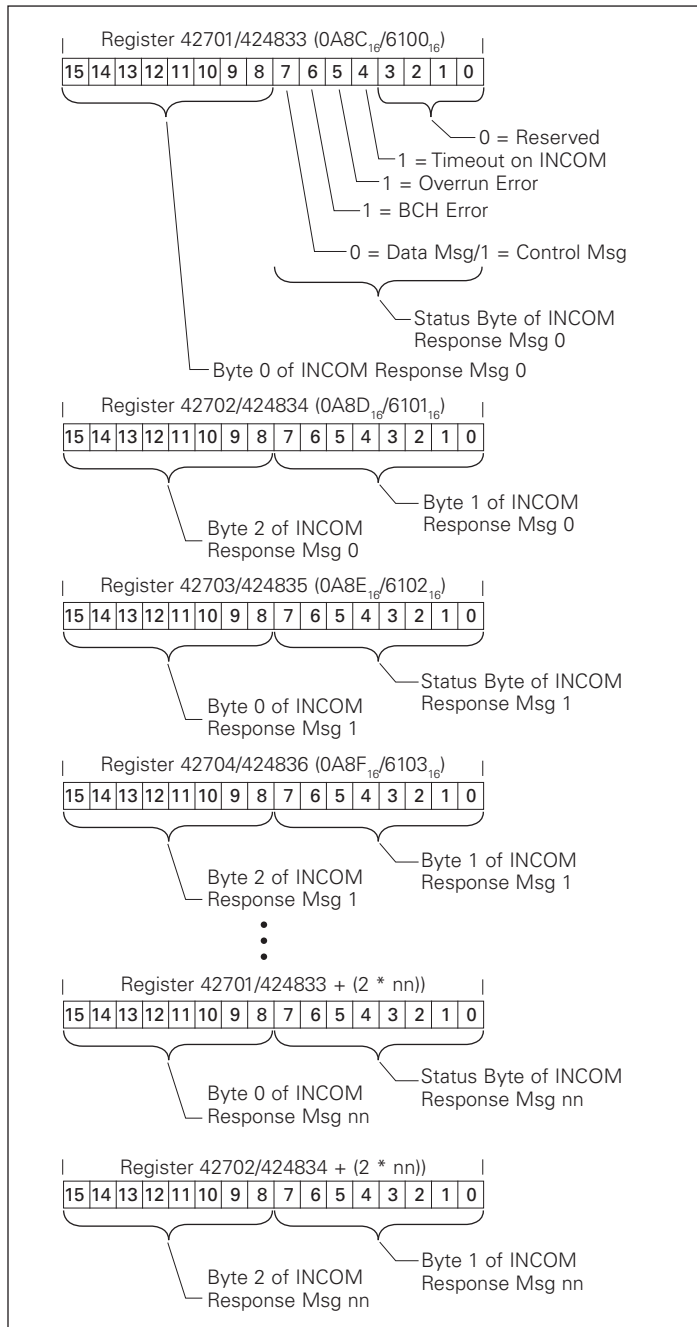

Figure 7. Pass-through to INCOM product response data format

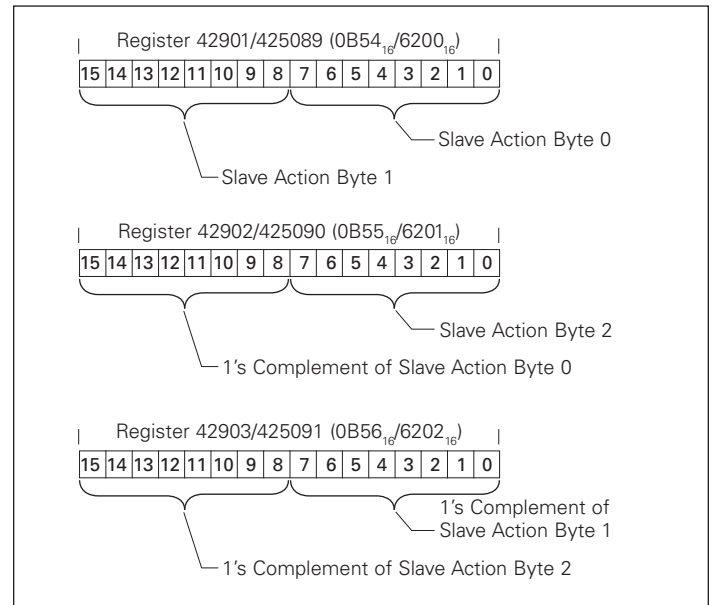

Figure 8. Control to INCOM product data format

Energy format

Energy objects in the mMINT are supported in 2-register fixed point object format and a 4-register power/mantissa format. These objects do not support IEEE floating point format.

The 2-register format is presented in units of Kwatthours and is valid for INCOM products reporting energy in watthours or Kwatthours only. Products reporting in units greater than Kwatthours (e.g., Mwatthours) could not guarantee consistent Kwatthour resolution up to and through their rollover values.

All products reporting energy (independent of energy units) support the energy objects occupying four registers—register 3 through register 0. Register 3 is the high order register and register 0 is the low order register.

Register 3 high byte contains a value corresponding to Engineering Units (power of 10 signed exponent). Register 3 low byte contains a Mantissa Multiplier value (power of 2 signed exponent).

Register 2 through register 0 contains a 48-bit energy mantissa in units of watthours. Net and total energy objects are signed values. All other energy objects are unsigned values.

The data format of these four registers is given in **Figure 9**.

$$\text{Energy} = 2^{\text{Mantissa Multiplier}} \times (48\text{-bit energy value}) \times 10^{\text{Engineering Units}}$$

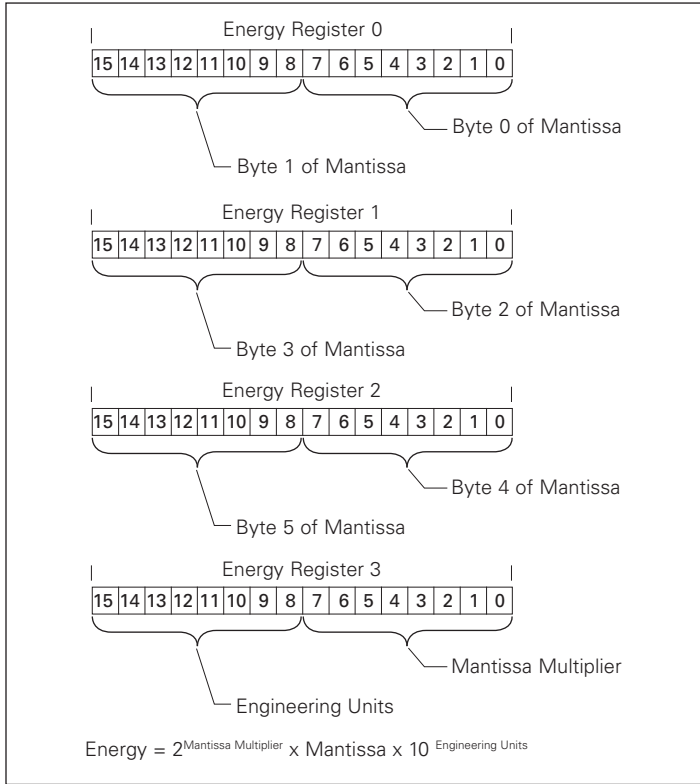

Figure 9. 4-register energy data format

Supported diagnostic sub-functions

It is possible to obtain diagnostics from the mMINT or an attached INCOM product using function code 08. See **Table 6**. A single register is used for each UART counter within the mMINT. Each INCOM device and the mMINT contain a unique slave counter.

To use mMINT address 247 or 248 in the diagnostic query, SW2-1 must be properly set. See Section 5 and **Table 5**.

Table 6. Diagnostic sub-function numbers

Sub-function Number (decimal)	Name	In the query use
0	echo query	mMINT or INCOM addr
1	restart communications	mMINT or INCOM addr
4	force listen	mMINT or INCOM addr
10	clear slave counters	mMINT or INCOM addr
11	UART bus message count	mMINT or INCOM addr
12	UART communication error count	mMINT or INCOM addr
13	slave exception error count	mMINT or INCOM addr
14	slave message count	mMINT or INCOM addr
15	slave no response count	mMINT or INCOM addr
16	slave NAK count	mMINT or INCOM addr
17	slave busy count	mMINT or INCOM addr
18	UART over run error count	mMINT or INCOM addr
20	clear UART counters	mMINT or INCOM addr
21	slave INCOM BCH error count	INCOM device addr
22	slave INCOM over run count	INCOM device addr
23	UART framing error count	mMINT or INCOM addr
24	UART noise error count	mMINT or INCOM addr
25	UART parity error count	mMINT or INCOM addr
26	mMINT firmware version & rev	mMINT addr
27	mMINT firmware month & day	mMINT addr
28	mMINT firmware year	mMINT addr
29	remove INCOM device(s)	mMINT or INCOM addr
30	reset INCOM routing addresses	mMINT addr

Exception codes

Under certain circumstances, the mMINT will return an exception code.

If the function in the query is not supported by the mMINT, exception code 01 is returned in the response.

If the data (object) register is illegal, exception code 02 is returned in the response.

If the data value in the query is illegal, exception code 03 is returned.

If the slave INCOM product fails (usually a timeout), exception code 04 is returned.

In certain circumstances, an exception code 05 (ACK) is returned.

If the mMINT cannot perform the requested function, exception code 07 (NAK) is returned.

If only a partial register is used in the query, exception code 84 is returned.

Section 7: Troubleshooting

The most common issues experienced with the installation of an mMINT module are addressed below.

If you have any questions or need further information or instructions, please contact your local Eaton representative or the Customer Support Center at 877-ETN-CARE (877-386-2273).

Table 7. Troubleshooting guide

Symptom	Possible solution(s)
Status LED not flashing	Verify proper input power to module connector
Modbus Tx LED is flashing, but the module does not respond to master command requests	Verify communication cable is connected correctly from the master to the module (A, B, +, -) Verify the data transfer rate is correctly set using baud rate switch (SW2)
INCOM Tx LED is flashing, but the module does not respond to master command requests	Verify communication cable is connected correctly from the slave to the module Verify the product is set up for 9600 baud Verify that the termination switch (SW1) is set to ON at the last module
Removing an INCOM product and assigning its INCOM (Modbus) address to another (different) INCOM product, and exception codes are received from the INCOM product	Disconnect the reassigned product from the INCOM network Verify that the Modbus Master has sent at least two requests to the address of the product that was just disconnected Connect the reassigned INCOM product

Appendix A

Notes:

1. Modbus is a registered trademark of Schneider Electric.
2. mMINT modules use DIN rail mounting.
3. Control voltage is 120 Vac +/-20% or 24–125 Vdc.
4. Connectors are plug-in types from Phoenix contact.
5. Terminal Types (supplied with module) are 3-point, 4-point, and 5-point Phoenix contact.
 - MVSTBR2,5/3-STF-5,08 (Order No. 1835106)
 - MVSTBR2,5/4-STF-5,08 (Order No. 1835119)
 - MVSTBR2,5/5-STF-5,08 (Order No. 1835122)
6. INCOM communications cable is Eaton C-H style 2A957805G01 or Belden style 9463.
7. Set up switch SW1 to insert 100 ohm terminating resistor on last module in the INCOM network.
8. Set up switch SW2 to select data transfer rate on the Modbus network.
9. Set up switch SW3 to insert 121 ohm terminating resistor on last module in the Modbus network.
10. Power wiring is any approved 300 V, 10 A, 30–12 AWG (stranded or solid).
11. The register map for INCOM products is shown in register number order in **Table 8** and functional order in **Table 9**. Numeric entries indicated with an asterisk (*) have specific definitions dependent upon the particular INCOM product. These tables include only a partial list of applicable INCOM products; however, it contains a complete list of the INCOM objects directly supported by the mMINT. Due to the mMINT pass-through feature, all INCOM product objects are accessible by a Modbus master.
12. The primary and secondary codes are mapped to the high and low bytes, respectively, of registers 404609 (1200₁₆) and 406145 (1800₁₆). The primary status codes are shown in **Table 10**. The secondary status codes are shown in **Table 11**. The cause-of-status codes are mapped to registers 404610 (1201₁₆) and 406146 (1801₁₆). The cause-of-status codes are shown in **Table 12**.
13. Catalog number is MMINT.

Table 8. Modbus register map (in register number order)

Objects (complete list)			Register number		Modbus address		INCOM products (partial list)																	
Name	Numeric	Units	IEEE float	Fixed point (FP)	IEEE float (Hex)	Fixed point (FP) (Hex)	FP scale factor	IQ 200	DP-4000	IQ Analyzer	IQ Data	IQ Data Plus II	Digitrip™ OPTIM 550	Digitrip OPTIM 750	Digitrip OPTIM 1050	Digitrip 810	Digitrip 910	Digitrip 520MC	Digitrip 1150	IQ Transfer II	MP-3000	Digitrip 3000®	FP-5000	
Status cause	primary		404609 or 406145 hi byte		1200 or 1800 hi byte			■	■	■	■	■	■	■	■	■	■	■	■	■	■	■	■	■
	secondary		404609 or 406145 lo byte		1200 or 1800 lo byte			■	■	■	■	■	■	■	■	■	■	■	■	■	■	■	■	■
	cause		404610 or 406146		1201 or 1801			■	■	■	■	■	■	■	■	■	■	■	■	■	■	■	■	■
Current	I _A	A	404611	406147	1202	1802	10	■	■	■	■	■	■	■	■	■	■	■	■	■	■	■	■	
	I _B	A	404613	406149	1204	1804	10	■	■	■	■	■	■	■	■	■	■	■	■	■	■	■	■	
	I _C	A	404615	406151	1206	1806	10	■	■	■	■	■	■	■	■	■	■	■	■	■	■	■	■	
	I _G	A	404617	406153	1208	1808	10			■			■	■	■	■	■	■	■	■	■	■	■	
	I _N	A	404619	406155	120A	180A	10			■			■	■	■	■	■	■	■	■	■	■	■	
	I _{Avg}	A avg	404621	406157	120C	180C	10			■												■		■
L-L voltage	V _{AB}	V	404623	406159	120E	180E	10	■	■	■	■	■					■		■				■	
	V _{BC}	V	404625	406161	1210	1810	10	■	■	■	■	■					■		■				■	
	V _{CA}	V	404627	406163	1212	1812	10	■	■	■	■	■					■		■				■	
	V _{Lavg}	V avg	404629	406165	1214	1814	10			■														■
L-N voltage	V _{AN}	V	404631	406167	1216	1816	10	■	■	■	■	■									■		■	
	V _{BN}	V	404633	406169	1218	1818	10	■	■	■	■	■									■		■	
	V _{CN}	V	404635	406171	121A	181A	10	■	■	■	■	■									■		■	
	V _{LN}	V avg	404637	406173	121C	181C	10			■														■
N-G voltage	V _{NG}	V	404639	406175	121E	181E	10			■														
Peak current	peak I _A demand	A	404641	406177	1220	1820	10	■	■	■			■	■	■					■			■	■
	peak I _B demand	A	404643	406179	1222	1822	10	■	■	■			■	■	■					■			■	■
	peak I _C demand	A	404645	406181	1224	1824	10	■	■	■			■	■	■					■			■	■
	peak I _G demand	A	404647	406183	1226	1826	10						■	■	■									■
	peak I _N demand	A	404649	406185	1228	1828	10						■	■	■									■
Power	real three-phase (power)	W	404651	406187	122A	182A	1	■	■	■					■	■	■			■			■	
	reactive three-phase	var	404653	406189	122C	182C	1	■	■	■			■							■			■	
	apparent three-phase	VA	404655	406191	122E	182E	1	■	■	■										■			■	
Power factor	displacement three-phase	pf	404657	406193	1230	1830	100	■	■	■														■
	apparent	pf	404659	406195	1232	1832	100	■	■	■					■	■	■			■			■	
Frequency	freq	Hz	404661	406197	1234	1834	10	■	■	■	■	■								■			■	
K-factor	K-factor		404663	406199	1236	1836	1			■														
THD factor	THD factor		404665	406201	1238	1838	1			■														

Note: All objects are two registers in length unless specified otherwise.

Table 8. Modbus register map (in register number order) (continued)

Objects (complete list)			Register number		Modbus address		INCOM products (partial list)																		
Name	Numeric	Units	IEEE float	Fixed point (FP)	IEEE float (Hex)	Fixed point (FP) (Hex)	FP scale Factor	IQ 200	DP-4000	IQ Analyzer	IQ Data	IQ Data Plus II	Digitrip OPTIM 550	Digitrip OPTIM 750	Digitrip OPTIM 1050	Digitrip 810	Digitrip 910	Digitrip 520MC	Digitrip 1150	IQ Transfer II	MP-3000	Digitrip 3000	FP-5000		
Power	A ph	W	404667	406203	123A	183A	1	■	■																
	B ph	W	404669	406205	123C	183C	1	■	■																
	C ph	W	404671	406207	123E	183E	1	■	■																
	reactive A ph	var	404673	406209	1240	1840	1	■	■																
	reactive B ph	var	404675	406211	1242	1842	1	■	■																
	reactive C ph	var	404677	406213	1244	1844	1	■	■																
	apparent A ph	VA	404679	406215	1246	1846	1	■	■																
	apparent B ph	VA	404681	406217	1248	1848	1	■	■																
	apparent C ph	VA	404683	406219	124A	184A	1	■	■																
Power factor	displacement A ph	pf	404685	406221	124C	184C	100	■	■																
	displacement B ph	pf	404687	406223	124E	184E	100	■	■																
	displacement C ph	pf	404689	406225	1250	1850	100	■	■																
	apparent A ph	pf	404691	406227	1252	1852	100	■	■																
	apparent B ph	pf	404693	406229	1254	1854	100	■	■																
	apparent C ph	pf	404695	406231	1256	1856	100	■	■																
Power	peak demand	W	404697	406233	1258	1858	1	■	■	■	■	■	■	■	■	■	■	■	■	■	■	■	■	■	
Source 1	V _{AB}	V	404699	406235	125A	185A	10														■				
	V _{BC}	V	404701	406237	125C	185C	10														■				
	V _{CA}	V	404703	406239	125E	185E	10														■				
	freq	Hz	404705	406241	1260	1860	10														■				
Source 2	V _{AB}	V	404707	406243	1262	1862	10														■				
	V _{BC}	V	404709	406245	1264	1864	10														■				
	V _{CA}	V	404711	406247	1266	1866	10														■				
	freq	Hz	404713	406249	1268	1868	10														■				
Power	power (real three-phase)	W	404715	406251	126A	186A	1	■	■	■	■	■	■	■	■	■	■	■	■	■	■	■	■	■	
Power factor	pf (*)	pf	404717	406253	126C	186C	100	■	■	■	■	■	■	■	■	■	■	■	■	■	■	■	■	■	
Product ID	prod ID		404719 or 406255		126E or 186E			■	■	■	■	■	■	■	■	■	■	■	■	■	■	■	■	■	

Note: All objects are two registers in length unless specified otherwise.

Table 8. Modbus register map (in register number order) (continued)

Objects (complete list)			Register number				Modbus address		INCOM products (partial list)															
Name	Numeric	Units	IEEE float	Fixed point (FP)	IEEE float (Hex)	Fixed point (FP) (Hex)	FP scale factor	IO 200	DP-4000	IO Analyzer	IO Data	IO Data Plus II	Digitrip OPTIM 550	Digitrip OPTIM 750	Digitrip OPTIM 1050	Digitrip 810	Digitrip 910	Digitrip 520MC	Digitrip 1150	IO Transfer II	MP-3000	Digitrip 3000	FP-5000	
Frequency	freq	Hz	404721	406257	1270	1870	100	■	■	■	■	■								■			■	
(K) Energy	forward	kWh	N/A	406259	N/A	1872	1	■	■	■					■	■	■		■				■	
	reverse	kWh	N/A	406261	N/A	1874	1	■	■	■					■	■	■		■				■	
	total (*)	kWh	N/A	406263	N/A	1876	1	■	■	■	■			■	■	■	■		■				■	
Reactive (K) energy	lead	kvarhW	N/A	406265	N/A	1878	1	■	■	■													■	
	lag	kvarhW	N/A	406267	N/A	187A	1	■	■	■													■	
	net	kvarhW	N/A	406269	N/A	187C	1	■	■	■													■	
(K) Energy	apparent	kVAh	N/A	406271	N/A	187E	1	■	■	■										■			■	
Motor	phase unbalance	%	404737	406273	1280	1880	100															■		
	thermal capacity	%	404739	406275	1282	1882	100																■	
Temperature	motor winding 1	°C	404741	406277	1284	1884	1																■	
	motor winding 2	°C	404743	406279	1286	1886	1																■	
	motor winding 3	°C	404745	406281	1288	1888	1																■	
	motor winding 4	°C	404747	406283	128A	188A	1																■	
	motor winding 5	°C	404749	406285	128C	188C	1																■	
	motor winding 6	°C	404751	406287	128E	188E	1																■	
	motor bearing 1	°C	404753	406289	1290	1890	1																■	
	motor bearing 2	°C	404755	406291	1292	1892	1																■	
	load bearing 1	°C	404757	406293	1294	1894	1																■	
	load bearing 2	°C	404759	406295	1296	1896	1																■	
	auxiliary	°C	404761	406297	1298	1898	1																■	
	device temperature		°C	404763	406299	129A	189A	1																■
				404765	406301	129C	189C																	■
				404767	406303	129E	189E																	■
Energy (4 reg objects)	forward	Wh	N/A	406305	N/A	18A0	1	■	■	■				■	■	■		■					■	
	reverse	Wh	N/A	406309	N/A	18A4	1	■	■	■				■	■	■		■					■	
	total (*)	Wh	N/A	406313	N/A	18A8	1	■	■	■	■			■	■	■		■					■	
Reactive energy (4 reg objects)	lead	varh	N/A	406317	N/A	18AC	1	■	■	■													■	
	lag	varh	N/A	406321	N/A	18B0	1	■	■	■													■	
	net	varh	N/A	406325	N/A	18B4	1	■	■	■													■	
Energy (4 reg) (4 reg)	apparent	VAh	N/A	406329	N/A	18B8	1	■	■	■										■			■	
			N/A	406333	N/A	18BC																		

Note: All objects are two registers in length unless specified otherwise.

Table 8. Modbus register map (in register number order) (continued)

Objects (complete list)			Register number		Modbus address		INCOM products (partial list)																	
Name	Numeric	Units	IEEE float	Fixed point (FP)	IEEE float (Hex)	Fixed point (FP) (Hex)	FP scale factor	IO 200	DP-4000	IO Analyzer	IO Data	IO Data Plus II	Digitrip OPTIM 550	Digitrip OPTIM 750	Digitrip OPTIM 1050	Digitrip 810	Digitrip 910	Digitrip 520MC	Digitrip 1150	IQ Transfer II	MP-3000	Digitrip 3000	FP-5000	
Network voltage	A ph	V	404801	406337	12C0	18C0	10																	
	B ph	V	404803	406339	12C2	18C2	10																	
	C ph	V	404805	406341	12C4	18C4	10																	
Transformer voltage	A ph	V	404807	406343	12C6	18C6	10																	
	B ph	V	404809	406345	12C8	18C8	10																	
	C ph	V	404811	406347	12CA	18CA	10																	
Phasing voltage	A ph	V	404813	406349	12CC	18CC	10																	
	B ph	V	404815	406351	12CE	18CE	10																	
	C ph	V	404817	406353	12D0	18D0	10																	
	A ph direct	V	404819	406355	12D2	18D2	10																	
	A ph quadrature	V	404821	406357	12D4	18D4	10																	
	B ph direct	V	404823	406359	12D6	18D6	10																	
	B ph quadrature	V	404825	406361	12D8	18D8	10																	
	C ph direct	V	404827	406363	12DA	18DA	10																	
	C ph quadrature	V	404829	406365	12DC	18DC	10																	
	Pos seq direct	V	404831	406367	12DE	18DE	10																	
	Pos seq quadrature	V	404833	406369	12E0	18E0	10																	

Note: All objects are two registers in length unless specified otherwise.

Table 9. Modbus register map (in functional order)

Objects (complete list)			Register number				Modbus address				INCOM products (partial list)													
Name	Numeric	Units	IEEE float	Fixed point (FP)	IEEE float (Hex)	Fixed point (FP) (Hex)	FP scale factor	IQ 200	DP-4000	IQ Analyzer	IQ Data	IQ Data Plus II	Digitrip OPTIM 550	Digitrip OPTIM 750	Digitrip OPTIM 1050	Digitrip 810	Digitrip 910	Digitrip 520MC	Digitrip 1150	IQ Transfer II	MP-3000	Digitrip 3000	FP-5000	
Product ID	prod ID		404719 or 406255		126E or 186E			■	■	■	■	■	■	■	■	■	■	■	■	■	■	■	■	■
Status cause	primary		404609 or 406145 hi byte		1200 or 1800 hi byte			■	■	■	■	■	■	■	■	■	■	■	■	■	■	■	■	■
	secondary		404609 or 406145 lo byte		1200 or 1800 lo byte			■	■	■	■	■	■	■	■	■	■	■	■	■	■	■	■	■
	cause		404610 or 406146		1201 or 1801			■	■	■	■	■	■	■	■	■	■	■	■	■	■	■	■	■
Current	I _A	A	404611	406147	1202	1802	10	■	■	■	■	■	■	■	■	■	■	■	■	■	■	■	■	■
	I _B	A	404613	406149	1204	1804	10	■	■	■	■	■	■	■	■	■	■	■	■	■	■	■	■	■
	I _C	A	404615	406151	1206	1806	10	■	■	■	■	■	■	■	■	■	■	■	■	■	■	■	■	■
	I _G	A	404617	406153	1208	1808	10			■		■	■	■	■	■	■	■	■	■	■	■	■	■
	I _N	A	404619	406155	120A	180A	10			■		■	■	■	■	■	■	■	■	■	■	■	■	■
	I _{Avg}	A avg	404621	406157	120C	180C	10			■												■		■
	peak I _A demand	A	404641	406177	1220	1820	10	■	■	■			■	■	■					■			■	■
	peak I _B demand	A	404643	406179	1222	1822	10	■	■	■			■	■	■					■			■	■
	peak I _C demand	A	404645	406181	1224	1824	10	■	■	■			■	■	■					■			■	■
	peak I _G demand	A	404647	406183	1226	1826	10						■	■	■								■	
peak I _N demand	A	404649	406185	1228	1828	10						■	■	■										
L-L voltage	V _{AB}	V	404623	406159	120E	180E	10	■	■	■	■	■					■		■				■	
	V _{BC}	V	404625	406161	1210	1810	10	■	■	■	■	■					■		■				■	
	V _{CA}	V	404627	406163	1212	1812	10	■	■	■	■	■					■		■				■	
	V _{Lavg}	V avg	404629	406165	1214	1814	10			■														■
L-N voltage	V _{AN}	V	404631	406167	1216	1816	10	■	■	■	■	■								■			■	
	V _{BN}	V	404633	406169	1218	1818	10	■	■	■	■	■								■			■	
	V _{CN}	V	404635	406171	121A	181A	10	■	■	■	■	■								■			■	
	V _{LN}	V avg	404637	406173	121C	181C	10			■														■
N-G voltage	V _{NG}	V	404639	406175	121E	181E	10			■														
Source 1	V _{AB}	V	404699	406235	125A	185A	10														■			
	V _{BC}	V	404701	406237	125C	185C	10														■			
	V _{CA}	V	404703	406239	125E	185E	10														■			
	freq	Hz	404705	406241	1260	1860	10															■		
Source 2	V _{AB}	V	404707	406243	1262	1862	10														■			
	V _{BC}	V	404709	406245	1264	1864	10														■			
	V _{CA}	V	404711	406247	1266	1866	10														■			
	freq	Hz	4047134	406249	1268	1868	10															■		
Network voltage	A ph	V	404801	406337	12C0	18C0	10																	
	B ph	V	404803	406339	12C2	18C2	10																	
	C ph	V	404805	406341	12C4	18C4	10																	

Note: All objects are two registers in length unless specified otherwise.

Table 9. Modbus register map (in functional order) (continued)

Objects (complete list)			Register number				Modbus address				INCOM products (partial list)													
Name	Numeric	Units	IEEE float	Fixed point (FP)	IEEE float (Hex)	Fixed point (FP) (Hex)	FP scale factor	IQ 200	DP-4000	IQ Analyzer	IQ Data	IQ Data Plus II	Digitrip OPTIM 550	Digitrip OPTIM 750	Digitrip OPTIM 1050	Digitrip 810	Digitrip 910	Digitrip 520MC	Digitrip 1150	IQ Transfer II	MP-3000	Digitrip 3000	FP-5000	
Transformer voltage	A ph	V	404807	406343	12C6	18C6	10																	
	B ph	V	404809	406345	12C8	18C8	10																	
	C ph	V	404811	406347	12CA	18CA	10																	
Phasing voltage	A ph	V	404813	406349	12CC	18CC	10																	
	B ph	V	404815	406351	12CE	18CE	10																	
	C ph	V	404817	406353	12D0	18D0	10																	
	A ph direct	V	404819	406355	12D2	18D2	10																	
	A ph quadrature	V	404821	406357	12D4	18D4	10																	
	B ph direct	V	404823	406359	12D6	18D6	10																	
	B ph quadrature	V	404825	406361	12D8	18D8	10																	
	C ph direct	V	404827	406363	12DA	18DA	10																	
	C ph quadrature	V	404829	406365	12DC	18DC	10																	
	pos seq direct	V	404831	406367	12DE	18DE	10																	
	pos seq quadrature	V	404833	406369	12E0	18E0	10																	
	Frequency	freq	Hz	404661	406197	1234	1834	10	■	■	■	■	■							■				■
freq		Hz	404721	406257	1270	1870	100	■	■	■	■	■								■				■
Power	power (real three-phase)	W	404715	406251	126A	186A	1	■	■	■		■			■	■	■		■				■	
	peak demand	W	404697	406233	1258	1858	1	■	■	■		■			■	■	■		■				■	
	real three-phase (power)	W	404651	406187	122A	182A	1	■	■	■		■			■	■	■		■				■	
	reactive three-phase	var	404653	406189	122C	182C	1	■	■	■		■								■				■
	apparent three-phase	VA	404655	406191	122E	182E	1	■	■	■										■				■
	A ph	W	404667	406203	123A	183A	1	■		■														
	B ph	W	404669	406205	123C	183C	1	■		■														
	C ph	W	404671	406207	123E	183E	1	■		■														
	reactive A ph	var	404673	406209	1240	1840	1	■		■														
	reactive B ph	var	404675	406211	1242	1842	1	■		■														
	reactive C ph	var	404677	406213	1244	1844	1	■		■														
	apparent A ph	VA	404679	406215	1246	1846	1	■		■														
	apparent B ph	VA	404681	406217	1248	1848	1	■		■														
	apparent C ph	VA	404683	406219	124A	184A	1	■		■														

Note: All objects are two registers in length unless specified otherwise.

Table 9. Modbus register map (in functional order) (continued)

Objects (complete list)			Register number				Modbus address				INCOM products (partial list)													
Name	Numeric	Units	IEEE float	Fixed point (FP)	IEEE float (Hex)	Fixed point (FP) (Hex)	FP scale factor	IQ 200	DP-4000	IQ Analyzer	IQ Data	IQ Data Plus II	Digitrip OPTIM 550	Digitrip OPTIM 750	Digitrip OPTIM 1050	Digitrip 810	Digitrip 910	Digitrip 520MC	Digitrip 1150	IQ Transfer II	MP-3000	Digitrip 3000	FP-5000	
Power factor	pf (*)	pf	404717	406253	126C	186C	100	■	■	■	■				■	■	■		■				■	
	displacement 3 ph	pf	404657	406193	1230	1830	100	■	■	■													■	
	displacement A ph	pf	404685	406221	124C	184C	100	■		■														
	displacement B ph	pf	404687	406223	124E	184E	100	■		■														
	displacement C ph	pf	404689	406225	1250	1850	100	■		■														
	apparent A ph	pf	404691	406227	1252	1852	100	■		■														
	apparent B ph	pf	404693	406229	1254	1854	100	■		■														
	apparent C ph	pf	404695	406231	1256	1856	100	■		■														
	apparent	pf	404659	406195	1232	1832	100	■	■	■		■			■	■	■			■				■
K-factor	K-factor		404663	406199	1236	1836	1			■														
THD factor	THD factor		404665	406201	1238	1838	1			■														
(K) Energy	forward	kWh	N/A	406259	N/A	1872	1	■	■	■					■	■	■		■				■	
	reverse	kWh	N/A	406261	N/A	1874	1	■	■	■					■	■	■		■				■	
	total (*)	kWh	N/A	406263	N/A	1876	1	■	■	■	■			■	■	■		■					■	
	apparent	kVAh	N/A	406271	N/A	187E	1	■	■	■									■				■	
Energy (4 reg objects)	forward	Wh	N/A	406305	N/A	18A0	1	■	■	■					■	■	■		■				■	
	reverse	Wh	N/A	406309	N/A	18A4	1	■	■	■					■	■	■		■				■	
	total (*)	Wh	N/A	406313	N/A	18A8	1	■	■	■	■			■	■	■		■					■	
	apparent	VAh	N/A	406329	N/A	18B8	1	■	■	■									■				■	
Reactive (K) energy	lead	kvarh	N/A	406267	N/A	1878	1	■	■	■													■	
	lag	kvarh	N/A	406269	N/A	187A	1	■	■	■													■	
	net	kvarh	N/A	406271	N/A	187C	1	■	■	■													■	
Reactive energy (4 reg objects)	lead	varh	N/A	406317	N/A	18AC	1	■	■	■													■	
	lag	varh	N/A	406321	N/A	18B0	1	■	■	■													■	
	net	varh	N/A	406325	N/A	18B4	1	■	■	■													■	
Motor	phase unbalance	%	404737	406273	1280	1880	100																■	
	thermal capacity	%	404739	406275	1282	1882	100																■	
Temperature	motor winding 1	°C	404741	406277	1284	1884	1																■	
	motor winding 2	°C	404743	406279	1286	1886	1																■	
	motor winding 3	°C	404745	406281	1288	1888	1																■	
	motor winding 4	°C	404747	406283	128A	188A	1																■	
	motor winding 5	°C	404749	406285	128C	188C	1																■	
	motor winding 6	°C	404751	406287	128E	188E	1																■	
	motor bearing 1	°C	404753	406289	1290	1890	1																■	
	motor bearing 2	°C	404755	406291	1292	1892	1																■	
	load bearing 1	°C	404757	406293	1294	1894	1																■	
	load bearing 2	°C	404759	406295	1296	1896	1																■	
	auxiliary	°C	404761	406297	1298	1898	1																■	
	device temperature	°C	404763	406299	129A	189A	1																■	

Note: All objects are two registers in length unless specified otherwise.

Table 10. Primary status code definitions

Code	Definition	Code	Definition
0	Unknown	19	Phase A alarm
1	Open	20	Phase B alarm
2	Closed	21	Phase C alarm
3	Tripped	22	Neutral alarm
4	Alarmed	23	Ground/earth alarm
5	On	24	Phase AB alarm
6	Off	25	Phase BC alarm
7	Ready	26	Phase CA alarm
8	Starting	27	On good source
9	Operational	28	Running
10	Stopped	Reserved 29...251	
11	Locked-out		
12	Transferred		
13	Picked-up		
14	Phase A trip		
15	Phase B trip	252	Product-Specific Code 252
16	Phase C trip	253	Product-Specific Code 253
17	Neutral trip	254	Product-Specific Code 254
18	Ground/earth trip	255	Product-Specific Code 255

Table 11. Secondary status code definitions

Code	Definition	Code	Definition
0	Unknown	Reserved 9...27	
1	Not applicable		
2	Program mode		
3	Test mode		
4	Disabled		
5	Disarmed	28	Product-Specific Code 28
6	Controlled device failed to operate	29	Product-Specific Code 29
7	Powered up	30	Product-Specific Code 30
8	Alarm	31	Product-Specific Code 31

Table 12. Cause-of-status code definitions

Code	Definition	Code	Definition
0	Unknown	39	Diagnostic warning #1
1	Normal operating mode	40	Diagnostic failure #1
2	External condition #1	41	Low battery
3	Instantaneous phase overcurrent	42	Multiple causes
4	Instantaneous ground overcurrent	43	Diagnostic warning #2
5	Instantaneous neutral overcurrent	44	Diagnostic warning #3
6	Instantaneous residual overcurrent	45	Diagnostic warning #4
7	Phase inverse-time overcurrent	46	Diagnostic warning #5
8	Ground inverse-time overcurrent	47	Diagnostic warning #6
9	Neutral inverse-time overcurrent	48	Diagnostic warning #7
10	Residual inverse-time overcurrent	49	Diagnostic warning #8
11	Overvoltage	50	Diagnostic warning #9
12	Undervoltage	51	Diagnostic warning #10
13	Auxiliary overvoltage	52	Diagnostic failure #2
14	Auxiliary undervoltage	53	Diagnostic failure #3
15	Underfrequency	54	Diagnostic failure #4
16	Overfrequency	55	Diagnostic failure #5
17	Current unbalance	56	Diagnostic failure #6
18	Voltage unbalance	57	Diagnostic failure #7
19	Apparent power factor	58	Diagnostic failure #8
20	Displacement power factor	59	Diagnostic failure #9
21	Zone interlock phase	60	Diagnostic failure #10
22	Zone interlock ground	61	Long delay phase overcurrent
23	Watt	62	Short delay phase overcurrent
24	VA	63	Fixed instantaneous phase overcurrent #1
25	Var	64	Bad / missing rating plug
26	Power demand	65	Reverse power
27	VA demand	66	Fixed instantaneous phase overcurrent #2
28	Var demand	67	Reverse phase
29	Current demand	68	Reverse sequence
30	Total harmonic distortion	69	Phase current loss
31	Operations count	70	Phase voltage loss
32	Contact maintenance	71	Alarm active
33	Control via communications	72	Bad frame
34	Contact disagreement	73	Phase currents near pickup
35	Breaker failure	74	Lockout
36	Operation time exceeded	75	Making current release
37	Coil supervision	76	Fixed instantaneous phase overcurrent #3
38	Programmable logic	77	Set points error

Table 12. Cause-of-status code definitions (continued)

Code	Definition	Code	Definition
78	Over-temperature	120	Fail to sync on phase
79	Accessory bus	121	Fail to sync on frequency
80	Long delay neutral overcurrent	122	Fail to sync on voltage
81	External condition #2	123	Anti-backspin
82	Historical data	124	Zero speed
83	External condition #3	125	Time between starts
84	Ground fault (instantaneous or delay)	126	Source 1
85	Earth fault (instantaneous or delay)	127	Source 2
86	External condition #4	128	Start
87	External condition #5	129	Manual
88	External condition #6	130	Synchronizing
89	External condition #7	131	Starts per hour
90	External condition #8	132	Preferred source
91	External condition #9	133	Plant exerciser
92	Multiple external conditions	134	Neutral ground overvoltage
93	Motor bearing temperature	135	Safety interlock
94	Load bearing temperature	136	Real-time clock
95	Auxiliary temperature	137	High floating voltage
96	Winding temperature	138	Trip blocked
97	Local temperature	139	Incomplete sequence
98	External temperature	140	Cause N/A (none)
99	Rolled phase	141	Trip position
100	Per unit voltage	142	Voltage transient
101	Sensitive	143	Tamper
102	Deenergized	144	RTD
103	Non-sensitive	145	Differential
104	Time delayed sensitive	146	Frequency out of range
105	Breaker pumping	147	Sensor mismatch
106	Sub-network malfunction	148	Check auxiliary switch
107	Learning	149	Overcurrent
108	Offline	150	Time delayed watt-VAR
109	Test	151	Overcurrent watt-VAR
110	Jam	152	Power
111	Under load	Reserved 153...2043	
112	Delay ground overcurrent		
113	Calibration		
114	Emergency		
115	Torque limit		
116	Deceleration	2044	Product-Specific Code 2044
117	Voltage sag	2045	Product-Specific Code 2045
118	Voltage swell	2046	Product-Specific Code 2046
119	Programming error	2047	Product-Specific Code 2047

Table 13. Control 'Slave Action Number' definitions

Control group	Definition	Byte 2	Byte 1	Byte 0
Reset	Reset alarm	0	0	1
	Reset trip	0	0	2
	Reset (peak) demand-watts	0	0	4
	Reset energy (kilowatt hours)	0	0	8
	Reset device software	0	0	16 (10 ₁₆)
	Reset time stamped event data buffers	0	0	32 (20 ₁₆)
	Reset (synchronize) demand watts window	0	0	64 (40 ₁₆)
	Snapshot command	0	0	128 (80 ₁₆)
	Reset (peak) demand-currents	0	1	1
	Reset operations count (or trigger counters)	0	1	2
	Reset run time	0	1	3
	Reset all min./max. values	0	1	4
	Unlock waveform buffer (clear upload-in-progress)	0	1	5
	Reset discrete input counters	0	1	6
	Reset min./max. currents	0	1	13
	Reset min./max. L-L voltages	0	1	14
	Reset min./max. L-N voltages	0	1	15
	Reset min./max. PF-apparent	0	1	16
	Reset min./max. PF-displacement	0	1	17
	Reset min./max. power	0	1	18
	Reset min./max. current THD	0	1	19
	Reset min./max. voltage THD	0	1	20
	Reset min./max. per-phase power	0	1	22
	Reset op count, run time and override count	0	1	36
	Reset motor data maximum values	0	1	37
	Reset motor trip and alarm counters	0	1	38
	Reset locked-trigger # X (X = trigger number)	0	2	X
Reset source 1 available time	0	3	1	
Reset source 1 connect time	0	3	2	
Reset source 1 run time	0	3	3	
Reset source 2 available time	0	3	4	
Reset source 2 connect time	0	3	5	
Reset source 2 run time	0	3	6	
Reset load energized time	0	3	7	
Reset transfer status	0	3	8	
Reset tamper flag for sensor #X	0	4	X	
Circuit Breaker Open-Close	Open request	1	0	0
	Close request	1	0	1
	Trip request	1	0	2

Table 13. Control ‘Slave Action Number’ definitions (continued)

Control group	Definition	Byte2	Byte1	Byte0
Motor Start-Stop	No action	2	0	0
	Start fast forward	2	0	1
	Start fast reverse	2	0	2
	Stop	2	0	3
	Start	2	0	4
	Start slow forward	2	0	5
	Start slow reverse	2	0	6
	Set direction to forward	2	0	7
	Set direction to reverse	2	0	8
	Emergency override	2	0	10
System Control	Release time-stamped event buffer	3	0	0
	Capture waveform	3	0	1
	Reset INCOM slave-interface statistics	3	0	2
	Reset product-specific statistics	3	0	3
	Acknowledge triggered event(s)	3	0	4
	Reset sun-network master INCOM statistics	3	0	5
	Acknowledge energy-reset	3	0	6
	Acknowledge set points change buffer	3	0	7
	Release time-stamped minor event buffer	3	0	8
	Release time-stamped motor start profile buffer	3	0	9
Relay Control	Activate relay output #X (X = relay number 0–255)	4	1	X
	De-activate relay output #X (X = relay number 0–255)	4	2	X
Automatic Transfer Switch Control	Initiate ATS test	5	0	1
	Bypass TDNE/TDEN	5	0	2
	Initiate manual transfer	5	0	4
	Cancel ATS test	5	0	5
	Go to emergency	5	0	6
Cancel Go to emergency	5	0	7	

Table 14. mMINT configuration registers

Register definition	R/W	Register ₁₀		Modbus address ₁₆		No. of regs ₁₀
		Low	High	Low	High	
mMINT (247 or 248 addressed)						
Invalid Object Access Configuration	R/W	42001	425345	07D0	6300	1
Floating Pt Data Word Order Configuration	R/W	42002	425346	07D1	6301	1
Fixed Pt Data Word Order Configuration	R/W	42003	425347	07D2	6302	1
INCOM Routing Address Configuration	R/W	42101		0834		2 * 246
INCOM (device addressed)						
Mapped Block of Registers Configuration	R/W	41001	420481	03E8	5000	100
Mapped Block of Registers Data	R	41201	420737	04B0	5100	4 * 100
Modbus-to-INCOM Query	W	42601	424577	0A28	6000	2
Modbus-to-INCOM Response	R	42701	424833	0A8C	6100	2 * 63
Supervisory Control Query	R/W	42901	425089	0B54	6200	3

Disclaimer of warranties and limitation of liability

The information, recommendations, descriptions, and safety notations in this document are based on Eaton's experience and judgment, and may not cover all contingencies. If further information is required, an Eaton sales office should be consulted.

Sale of the product shown in this literature is subject to the terms and conditions outlined in appropriate Eaton selling policies or other contractual agreement between Eaton and the purchaser.

THERE ARE NO UNDERSTANDINGS, AGREEMENTS, WARRANTIES, EXPRESSED OR IMPLIED, INCLUDING WARRANTIES OF FITNESS FOR A PARTICULAR PURPOSE OR MERCHANTABILITY, OTHER THAN THOSE SPECIFICALLY SET OUT IN ANY EXISTING CONTRACT BETWEEN THE PARTIES. ANY SUCH CONTRACT STATES THE ENTIRE OBLIGATION OF EATON. THE CONTENTS OF THIS DOCUMENT SHALL NOT BECOME PART OF OR MODIFY ANY CONTRACT BETWEEN THE PARTIES.

In no event will Eaton be responsible to the purchaser or user in contract, in tort (including negligence), strict liability, or otherwise for any special, indirect, incidental, or consequential damage or loss whatsoever, including but not limited to damage or loss of use of equipment, plant or power system, cost of capital, loss of power, additional expenses in the use of existing power facilities, or claims against the purchaser or user by its customers resulting from the use of the information, recommendations, and descriptions contained herein.

The information contained in this manual is subject to change without notice.

Eaton
1000 Eaton Boulevard
Cleveland, OH 44122
United States
Eaton.com

© 2016 Eaton
All Rights Reserved
Printed in USA
Publication No. IL66A7508H09 / Z18808
October 2016