

5MP, IR, 4x, ACTIVE DETERRENCE MINI-PTZ DOME



4x PTZ Dome

IPCSD54X

- > Fully Adheres to National Defense Authorization Act (NDAA) Guidelines
- > Exceptional Video Quality with 5MP 2880 x 1620 Resolution, with Super-Efficient H.265 Video Compression for Drastically Reduced Bandwidth and Storage
- > LightHunter Technology for ultra-high image quality in low light applications and Smart IR LED Lights for 0 Lux Night Time Operation up to 164 Feet
- > 2.8 ~ 12mm, 4x Optical motorized zoom and automatic focus lens
- > TRUE Day/Night and Wide Dynamic Range Functionality for all Lighting Conditions
- > Built-In Mic & Speaker, Backlight Compensation and 3D DNR (Digital Noise Reduction)
- > Pan / Tilt Speed up to 50°/sec with up to 256 Preset Positions
- > Triple Video Streams; ONVIF Profile S Compliant
- > Intelligent perimeter protection with Active Deterrence with Strobe Light and Audio Alarm
- > 12VDC / PoE Power Options and Built-in Micro-SD Card Slot enables up to 256GB storage
- > Supported by uniview tec Guard Station Software and Guard Viewer Mobile App's for iPhone and Android Devices

www.univiewtechnology.com



UVT7630421-03

Specifications

Camera	
Sensor	1/2.7", progressive scan , 5 megapixel CMOS
Lens	2.8 ~ 12mm, automatic focusing and motorized zoom lens
Angle of View (H x V)	30.6° ~ 104.1° x 17.4° ~ 54.9°(wide ~ tele)
Shutter	Auto/Manual, 1 ~ 1/100000 s
Minimum Illumination	Color: 0.003 Lux (F1.6, AGC ON); 0 Lux with IR
Day/Night	IR-cut filter with auto switch (ICR)
Digital noise reduction	2D/3D DNR
IR LED Range / Wavelength	Up to 50m (164ft) IR range / 850nm
WDR	120dB
Video Compression	Ultra 265, H.265, H.264, MJPEG
Maximum Frame Rate / Stream	Main Stream: 5MP (2880 × 1620) @ 30fps Sub Stream: 720P (1280 × 720) @ 30fps Third Stream: D1 (720 × 576) @ 30fps
HLC, BLC, Flip	Supported
OSD, Privacy Mask, Motion Detection & ROI	Up to 8 areas
Pan and Tilt Speed; Presets	0°~345° Pan, 50°/s max speed; -10° ~ 110° Tilt, 40°/s max speed; 256 presets
Network	
Protocols	IPv4, IGMP, ICMP, ARP, TCP, UDP, DHCP , PPPoE, RTP, RTSP, RTCP, DNS, DDNS, NTP, FTP, UPnP, HTTP, HTTPS, SMTP , 802.1x , SNMP, SSL
Compatible Integration	ONVIF Profile S, API
Network	RJ45, 10M/100M Base-TX Ethernet
Intelligent Perimeter Protection	Cross Line, Intrusion, Enter Area, Leave Area detection; Motion detection
Local & Network Storage	Micro-SD, up to 256GB; Automatic Network Replenishment (ANR)
General	
Power	12VDC +/- 25%, PoE (IEEE802.3 af); Max 18W
Dimensions (Ø x H) & Weight	Φ133 x 269.4mm (Φ5.2 x 10.6"); 1.13kg (2.49lb)
Audio Features & Compression	Built-in Mic & Speaker; G.711U and G.711A
Operating Temperature & Humidity	-20°C ~ +60°C (-4°F ~ 140°F); Humidity: 10%~95% RH (non-condensing)
Conformity Certifications	IP66, CE, FCC

Dimensions

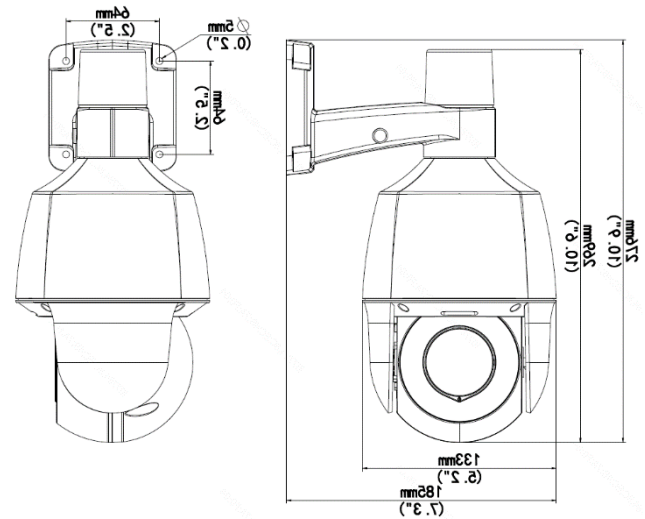

Accessories

See Camera Accessories Guide