

ENFORCER®

Wireless Intercom

Manual



DP-T100-2Q	Wireless Intercom Starter Kit – 2 Intercoms
DP-T100-1Q	Wireless Intercom – Single Intercom

Features:

- Simple and easy setup
- Encrypted transmission offers security and protection
- Range up to 1,000ft (300m)*
- 4 Selectable channels
- Connect up to 16 wireless intercoms
- Each intercom has adjustable volume
- Indicator LEDs show mode and status
- Powered by batteries (alkaline or rechargeable) or power adapter (both not included)
- 4 Communication modes: full broadcast to all stations, talk on a single channel, private talk, and hands free
- Fail-safe design: if an intercom loses connection it automatically reconnects to other intercoms

*Line-of-sight range. Actual range may vary depending on the installation and operating environment.

ENFORCER Wireless Intercom

Table of Contents:

Introduction	2
Parts List.....	2
Specifications.....	2
Dimensions	2
Overview.....	3
Installation Notes.....	3
Powering the Wireless Intercom.....	3
Power Controls.....	4
Setup.....	4
Basic Controls and Modes	5
Operation:.....	6-7
Troubleshooting.....	7
Notes	7
Also Available.....	8

Introduction:

The ENFORCER Wireless Intercom is a simple and secure way to communicate between multiple intercoms (up to 16 units, total) within an area of up to 1,000ft (300m).¹ The wireless intercoms operate on 4 channels and can either broadcast to all intercoms or to select intercoms on the same channel.

Parts List:

2x Wireless Intercom Units²

1x Manual

Specifications:

Power	12VDC/500mA adapter (2.1mm) or 1.5V AA alkaline/rechargeable batteries x 4 ³
Low battery voltage	4.2VDC
Frequency	902-928 MHz (frequency hopping)
Number of channels	4
Maximum RF Power	57.2mW
Range	1,000' ¹ (300m) ¹
Dimensions	7 1/2"x3 1/2"x1 1/4" (190x89x32 mm)
Weight	5.3-oz (150g)

Dimensions:

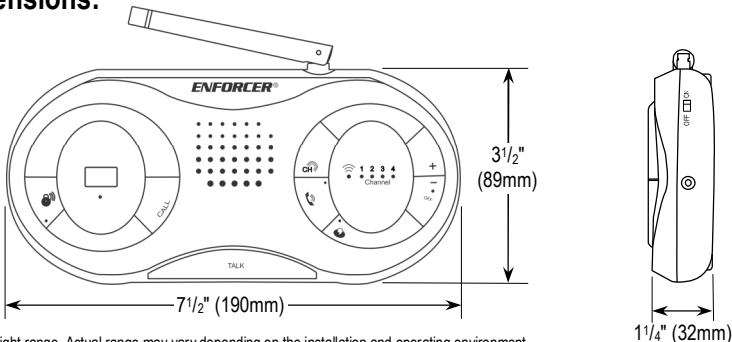

¹Line-of-sight range. Actual range may vary depending on the installation and operating environment.

²DP-T100-2Q only. DP-T100-1Q comes with a single wireless intercom.

³Batteries and power adapter not included.

Overview:

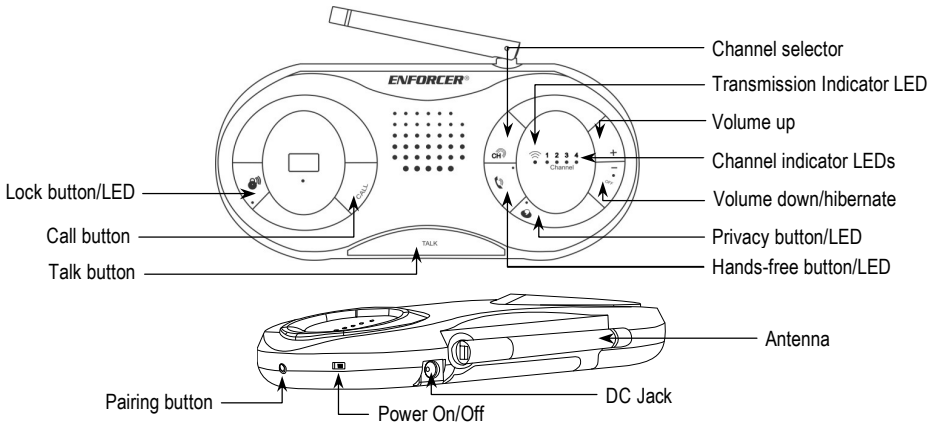

NOTE: Intercoms can handle multiple channels communicating simultaneously without interference.

Installation Notes:

1. Unpack the wireless intercom and note the included parts.
2. Read this manual thoroughly. A clear understanding of the manual will make installation and operation much easier.
3. Find a good location to mount or set the units (desk, wall, etc.).
4. The intercom contains no user-serviceable parts. Opening them may damage sensitive components and will void the warranty.

Powering the Wireless Intercom:

The wireless intercoms may be powered by 4 AA batteries (alkaline or rechargeable) or by a 12VDC power adapter (both not included).

Battery Installation

1. Press and slide battery cover open (see Fig. 1).
2. Insert 4 AA batteries (not included) into the battery compartment (see Fig. 2).

Important: To use rechargeable batteries and charge them using a power adapter, slide the battery mode switch to the **●** position (see Fig. 3). For alkaline batteries, you **must** leave the battery mode switch in the **⊗** position (default). Failure to do so may result in damage to the unit.

Power Adapter (not included)

Plug a 12VDC power adapter into the DC jack.

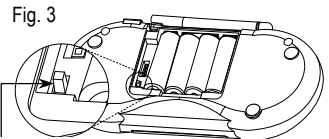
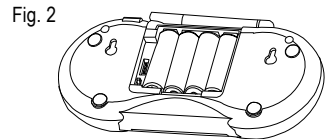
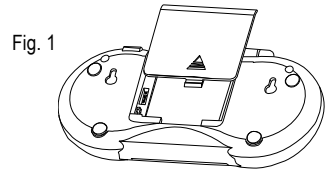

Battery mode switch

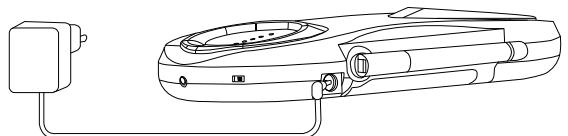

Power Controls:

Power Switch

Turn the unit on by sliding the power switch to the on position. The transmission indicator LED will flash and the channel indicator will blink to indicate the unit is searching for a signal. Once a signal is found, the channel indicator will stop blinking and the unit will click. Turn the intercom off by sliding the power switch to the off position.

Hibernate Mode

Press and hold the volume down button for 5 seconds to put the unit into hibernate mode (indicated by a beep, a single flash of the transmission indicator LED, and three flashes of the channel LEDs). During hibernate mode, the unit cannot receive calls.

Wake from Hibernate Mode

Press any key on the unit to wake it. The channel indicator will begin to blink. Once a signal is found, the channel indicator will stop blinking and the intercom will beep.

Setup:

Clearing Codes

Before setting up a new system, you must clear any preexisting codes from all of the intercoms.

1. Press and release the pairing button on one of the intercoms once. The channel indicator LEDs will flash in sequence indicating that it is now in pairing mode.
2. Press and hold the pairing button for 5 seconds until the channel indicator LEDs turn off, the power LED flashes, and you hear a beep, indicating that preexisting codes have been cleared.

NOTE: When adding a new intercom to the system, you must first clear any preexisting codes on the new intercom.

Setting Up a New Wireless Intercom System

1. Clear any preexisting codes from all of the intercoms as described above.
2. Press the pairing button on one of the intercoms. The channel indicator LEDs will flash in sequence. (The first intercom to enter pairing mode becomes the primary intercom.)
3. Within 60 seconds, press the pairing button on the other intercom. The channel indicator LEDs will flash in sequence. When pairing is successful, the channel indicator LEDs of both units will stop flashing.

NOTE: If a wireless intercom loses connection, it will automatically reconnect to other intercoms.

Adding a Wireless Intercom to an Existing System

1. Make sure that any preexisting codes on the new intercom are cleared.
2. Press the pairing button on any intercom that has already been paired. The channel indicator will flash in sequence on this intercom.
3. Within 60 seconds, press the pairing button on the new intercom. The channel indicator LEDs on this intercom will flash in sequence. Once pairing is complete, the channel indicator LEDs of both units will stop flashing.
4. Repeat the above steps to pair additional intercom units, up to a total of 16 intercom units.

Basic Controls and Modes:

Call Button

Press the call button to ring all intercoms on the same channel (or all channels if in broadcast mode (see "Broadcast Mode" below).

Talk Button

Press and hold the talk button to speak. The conversation will be heard by all intercom units on the same channel. Two units on the same channel cannot transmit at the same time. *When the transmission LED () is lit the talk button is inactive.*

Volume Control Buttons

Press and release the volume up and volume down buttons to adjust the volume of the intercom. The intercom will beep to indicate the volume level. There are five volume levels.

Channel Selection Button

The wireless intercom supports four separate channels and a broadcast mode. To cycle between channels, simply press the channel button (). The channel indicator LEDs show the currently active channel (1, 2, 3, 4, or 1234).

The intercom is in broadcast mode when all four LEDs are lit. In this mode, the intercom can receive messages from all channels and can transmit messages to all channels. Note that *privacy mode cannot be activated in broadcast mode* and any messages received in broadcast mode will not be private even if the sending unit has privacy mode set (see "Privacy Mode" below).

Hands-free Button

Press the hands-free button () to enter hands-free mode. In this mode, intercom transmission is activated by sound without pressing the talk button. There may be some delay, resulting in clipping of the first sounds and this mode will not work well in areas with high background noise. Press the hands-free button again to exit this mode. Hands-free mode is also cancelled if the channel selection button is pressed.

Lock Button

Press the lock button (). The lock indicator LED will light and the intercom will be locked in transmitting mode. This is useful for monitoring an area. However, if a listening unit leaves that channel it will no longer be able to monitor the locked unit even if the listener returns to the channel later. Press the lock button again to unlock.

NOTE: The lock button leaves the unit continuously transmitting and will tie up that channel. Hands-free mode is sound-activated and will only transmit when sound is detected.

Low Battery Indicator

When the battery voltage is low, the power and channel LEDs will blink every 20 seconds.

Privacy Button

When either unit has privacy mode set and neither are in broadcast mode, messages between them will be private. Privacy mode cannot be set in broadcast mode, and calls to another unit that is in broadcast mode will not be private. For privacy, ask the receiver to leave broadcast mode.

NOTE: Any pause of 10 seconds between transmissions will break that private conversation channel. The private conversation is only reestablished on the second transmission from the unit with privacy mode set.

Operation:

To use the ENFORCER Wireless Intercom system, it is helpful to understand a few principles.

General Conversations

1. Press the call button once and all other units on the same channel (or all channels when in broadcast mode – see "Broadcast Mode" on pg. 5) will ring.
2. When any unit presses the talk button, a conversation is established, but note that the conversation is public to all on the same channel and all can join in.

NOTE: Selecting broadcast mode means that unit is connected to all channels. If any unit has broadcast mode selected, that unit will send to and receive from all channels. If other units have selected specific channels, their replies will not be heard by others who are not on their channel.

Open Conversations



For a message to all on the same channel, either press the call button and wait for an answer, or just press the talk button and speak. All who are on that channel will hear the message and all responses will be heard by all on the responders' channel.

Private Conversations

Private conversations are only established when neither unit is in broadcast mode and both are on the same channel.

NOTE: Because private conversations require an initial 'handshake' between two units, it is recommended to first press the call button. If starting with the talk button, the first messages both ways will be public.

To initiate a private conversation:

1. To make a private call, press the privacy button () once before a call. The privacy indicator LED lights to indicate you are in privacy mode. Press the call button and other intercoms on the same channel will ring. A private call is established when the talk button on another intercom is pressed within 10 seconds. The other unit's privacy LED will also light while the user presses the talk button to indicate that they are private. Note that, since the caller cannot know whether or not the receiver is in broadcast mode, *if privacy is important, you should remind them to change to the single channel that you are on, and start the call again.*
2. When a conversation is established in privacy mode, the channel will be locked to these two units for approximately 6 seconds after each transmission in order to retain the private conversation and prohibit a third party from joining or interrupting. During this time, the transmission LED () on all other units on the same channel will remain lit to indicate that the channel is currently tied up.
3. If someone waits more than 10 seconds to press the talk button, their reply will not be private and will go to all on the same channel, but if you press talk within 10 seconds of hearing their message, a private conversation will be established with that unit after your initial reply.

ENFORCER Wireless Intercom

Also Available from **SECO-LARM®**:

Wireless Video Door Phone



DP-236Q

Hands-Free Video Door Phone



DP-234Q

Wireless Desktop Transmitter



SD-862T-GWSQ

1-Channel RF Receiver



SK-910RBQ

1-Button, 1-Channel Handheld RF Transmitter



SK-919TP1H-BUQ

1-Channel RF Transmitter



SK-919TD1S-UPQ

Receivers and Transmitters also available in 2, 3, and 4 channel versions.

IMPORTANT: Users and installers of this product are responsible for ensuring this product complies with all national, state, and local laws and statutes related to monitoring and recording audio and video signals. SECO-LARM will not be held responsible for the use of this product in violation of any current laws or statutes.

WARNING: Stop using this product and disconnect it from power if you see a malfunction such as smoke or unusual heat, as it could cause fire or electric shock. Do not open the case of this device as there are no field-serviceable components inside.

FCC COMPLIANCE STATEMENT

FCC ID: YAHINTXX1

THIS DEVICE COMPLIES WITH PART 15 OF THE FCC RULES. OPERATION IS SUBJECT TO THE FOLLOWING TWO CONDITIONS: (1) THIS DEVICE MAY NOT CAUSE HARMFUL INTERFERENCE AND (2) THIS DEVICE MUST ACCEPT ANY INTERFERENCE RECEIVED, INCLUDING INTERFERENCE THAT MAY CAUSE UNDESIRED OPERATION.

Notice: The changes or modifications not expressly approved by the party responsible for compliance could void the user's authority to operate the equipment.

IMPORTANT NOTE: To comply with the FCC RF exposure compliance requirements, no change to the antenna or the device is permitted. Any change to the antenna or the device could result in the device exceeding the RF exposure requirements and void user's authority to operate the device.

WARRANTY: This SECO-LARM product is warranted against defects in material and workmanship while used in normal service for one (1) year from the date of sale to the original customer. SECO-LARM's obligation is limited to the repair or replacement of any defective part if the unit is returned, transportation prepaid, to SECO-LARM. This Warranty is void if damage is caused by or attributed to acts of God, physical or electrical misuse or abuse, neglect, repair or alteration, improper or abnormal usage, or faulty installation, or if for any other reason SECO-LARM determines that such equipment is not operating properly as a result of causes other than defects in material and workmanship. The sole obligation of SECO-LARM and the purchaser's exclusive remedy, shall be limited to the replacement or repair only, at SECO-LARM's option. In no event shall SECO-LARM be liable for any special, collateral, incidental, or consequential personal or property damage of any kind to the purchaser or anyone else.

NOTICE: The SECO-LARM policy is one of continual development and improvement. For that reason, SECO-LARM reserves the right to change specifications without notice. SECO-LARM is also not responsible for misprints. All trademarks are the property of SECO-LARM U.S.A., Inc. or their respective owners. Copyright © 2017 SECO-LARM U.S.A., Inc. All rights reserved.

SECO-LARM® U.S.A., Inc.

16842 Millikan Avenue, Irvine, CA 92606
Phone: (949) 261-2999 | (800) 662-0800

Website: www.seco-larm.com
Email: sales@seco-larm.com

 PIHV1

ML_DP-T100-xQ_1701006.docx