

Industrial Wide-Gap Magnetic Contacts

SM-4601-LQ

3" (76mm) Gap, Closed Loop, Armored Leads, UL Listed

SM-4601-L3Q

3" (76mm) Gap, Open/Closed Loop, Armored Leads

Features

- Useful for industrial situations where a wide-gap, surface mount contact is needed
- 36" (91cm) Wire leads enclosed in armored cable
- Contact switch has iridium-plating for a high melting point and Vickers hardness for higher power handling and a longer expected life
- Weatherproof (IP65) and sealed for outdoor use
- Rugged aluminum housing
- 3" (76mm) Gap
- Mounting bracket included
- Lifetime limited warranty



SM-4601-LQ shown



SM-4601-LQ only



Specifications

| Model | SM-4601-LQ | SM-4601-L3Q |
|--------------------------|---------------------------------|--------------------------|
| Loop type | Closed | Open/closed |
| Electrical configuration | N.O. (SPST) | NO/NC (Form C – SPDT) |
| Operation gap | 3" (76mm) | |
| Connectors | 36" (91cm) Armored leads | |
| Material | Case | Aluminum |
| | Contacts | Iridium-plated |
| Contact Rating | 1.0A@10VDC (max.) 10W (max.) | |
| Switch cycles | 50 Million (0.1mA@5VDC) | |
| IP Rating | IP65 Weatherproof | |
| Operating temperature | -15°~160° F (-25°~70° C) | |
| Dimensions | Switch | 3"x1"x1/2" (76x25x13 mm) |
| | Magnet | 3"x1"x1/2" (76x25x13 mm) |
| Magnet | Rare-earth neodymium | |

Dimensions

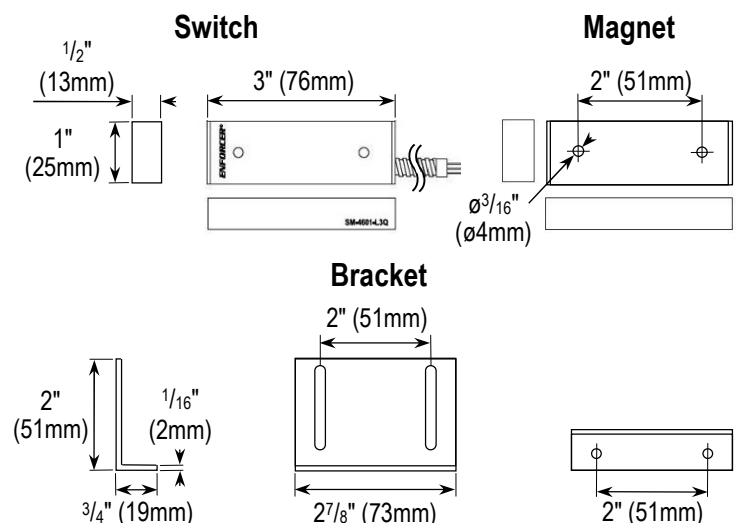

SECO-LARM® U.S.A., Inc.

16842 Millikan Avenue, Irvine, CA 92606

Phone: (949) 261-2999 | (800) 662-0800 Fax: (949) 261-7326

Website: www.seco-larm.com Email: sales@seco-larm.com



Copyright © 2022 SECO-LARM U.S.A., Inc. All rights reserved. All trademarks are the property of SECO-LARM U.S.A., Inc. or their respective owners. The SECO-LARM policy is one of continual development. For that reason, SECO-LARM reserves the right to change prices and specifications without notice. SECO-LARM is not responsible for misprints.

SECO-LARM® ENFORCER® CRIMEBUSTER® CBA® SLI®

PI_SM-4601-LxQ_220414_ML.docx

Contactos Magnéticos Industriales de Amplia Brecha

SM-4601-LQ Brecha de 3" (76mm), Circuito Cerrado, Cables Blindados, UL Listed

SM-4601-L3Q Brecha de 3" (76mm), Circuito Abierto/Cerrado, Cables Blindados



Sola SM-4601-LQ

Características

- Útil para situaciones industriales donde una amplia brecha, superficie se necesita contacto de montaje
- Cables de alambre de 36" (91 cm) encerrados en cable blindado
- El interruptor de caña de contacto está chapado en iridio para tener una alta fusión punto y dureza Vickers para un mayor manejo de potencia y vida esperada más larga
- Resistente a la intemperie (IP65) y sellado para uso en exteriores
- Carcasa de aluminio resistente
- Brecha de 3" (76mm)
- Soporte de montaje incluido
- Garantía limitada de por vida



SM-4601-LQ mostrado



Contactos Chapados en Iridio

Imán de Ferrita

36" Cables Blindados

Brecha de 3"

Especificaciones

| | | |
|-------------------------|---------------------------------|--------------------------|
| Model | SM-4601-LQ | SM-4601-L3Q |
| Tipo de circuito | Cerrado | Abierto/cerrado |
| Configuración eléctrica | N.A. (SPST) | NA/NC (Form C – SPDT) |
| Brecha de operación | 3" (76mm) | |
| Conectores | 36" (91cm) Cables blindados | |
| Material | Caja | Aluminio |
| | Contactos | Chapado en iridio |
| Puntuación de contactos | 1.0A@10VCC (max.) | |
| | 10W (max.) | |
| Ciclos de conmutación | 50 Millones; (0.1mA@5VCC) | |
| Clasificación IP | IP65 Resistente a la intemperie | |
| Temperatura | -15°~160° F (-25°~70° C) | |
| Dimensiones | Interruptor | 3"x1"x1/2" (76x25x13 mm) |
| | Imán | 3"x1"x1/2" (76x25x13 mm) |
| Imán | Neodimio de tierras raras | |

Dimensiones

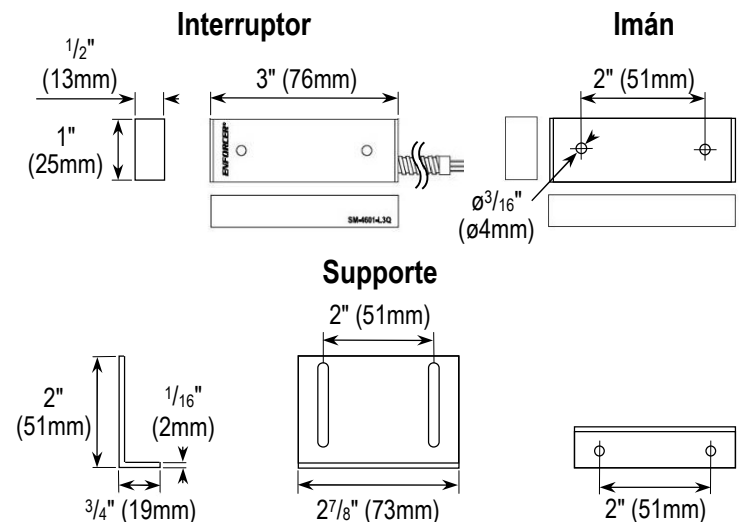

SECO-LARM® U.S.A., Inc.

16842 Millikan Avenue, Irvine, CA 92606

Phone: (949) 261-2999 | (800) 662-0800 Fax: (949) 261-7326

Website: www.seco-larm.com Email: sales@seco-larm.com



Copyright © 2022 SECO-LARM U.S.A., Inc. Todos los derechos reservados. Todas las marcas comerciales son propiedad de SECO-LARM U.S.A., Inc. o sus respectivos propietarios. La póliza de SECO-LARM es de desarrollo y mejora continua. Por esa razón, SECO-LARM se reserva el derecho de cambiar las especificaciones y los precios sin previo aviso. SECO-LARM tampoco es responsable de errores de impresión.

SECO-LARM® ENFORCER® CRIMEBUSTER® CBA® SLI®

PI_SM-4601-LxQ_220414_ML.docx