



**SILENT
KNIGHT**

by Honeywell

SKE-SERIES

**Voice
Evacuation**

**Installation and
Operations Manual**

Part Number 151267 Rev E

Contents

Section 1

Overview 1-1

- 1.1 Features 1-1
- 1.2 Optional Accessories 1-2
- 1.3 About This Manual 1-2
- 1.4 How to Contact Silent Knight 1-2

Section 2

Agency Listings, Approvals, and Requirements 2-1

- 2.1 FCC Warning 2-1
- 2.2 Underwriters Laboratories (UL) 2-1
 - 2.2.1 Requirements for All Installations 2-1
 - 2.2.2 Requirements for Local Protected Fire Alarm Systems 2-1

Section 3

Installation 3-1

- 3.1 Environmental Specifications 3-1
- 3.2 Electrical Specification 3-1
- 3.3 Board Layout 3-2
 - 3.3.1 Wiring Overview 3-3
 - 3.3.2 Terminal Strip 1 3-4
 - 3.3.3 Terminal Strip 2 3-4
 - 3.3.4 Earth Fault Resistance 3-5
 - 3.3.5 System LEDs 3-6
 - 3.3.6 Microphone Connection 3-7
 - 3.3.7 RS-232 Serial Connector 3-7
 - 3.3.8 Microphone (MIC) Gain 3-7
 - 3.3.9 S1 & S2 Message Test Buttons 3-7
 - 3.3.10 AC Delay Switch 3-8
- 3.4 Mounting the Control Panel 3-8
 - 3.4.1 Preventing Water Damage 3-8
 - 3.4.2 Wiring Specifications 3-9
- 3.5 Mounting the Main Control Board in the Cabinet 3-10
- 3.6 Speaker Wiring 3-11
 - 3.6.1 Wiring Lengths 3-11
 - 3.6.2 Class B (Style Y) 3-12
 - 3.6.3 Class A (Style Z) 3-12

3.7	Input Circuits	3-13
3.7.1	CMD1 Input Circuit	3-13
3.7.1.1	Class B (Style Y)	3-13
3.7.1.2	Class A (Style Z)	3-14
3.7.2	CMD2 Input Circuit	3-14
3.8	Connecting Power	3-15
3.8.1	AC Power	3-15
3.8.2	Backup Battery Power	3-17

Section 4

Programming

4.1	DIP Switch Programming	4-1
4.2	Recording Custom Message	4-3
4.2.1	Input Message 3 From the Microphone	4-4
4.2.1.1	Record Message 3 Using the Microphone	4-4
4.2.1.2	To Erase Message 3	4-4
4.2.2	Input Message 3 From a PC	4-4
4.2.2.1	Using the Aux Audio input	4-5
4.2.2.2	Using 7780 Software	4-6

Section 5

SKE-ZN4 Zone Splitter

5.1	SKE-ZN4 Board and Components	5-1
5.1.1	Terminal Strip 1	5-2
5.1.2	Terminal Strip 2	5-2
5.1.3	Terminal Strip 3	5-2
5.1.4	Terminal Strip 4	5-3
5.1.5	Terminal Strip 5	5-3
5.1.6	Manual Zone Switches	5-3
5.1.7	All Call Switch	5-4
5.1.8	Zone Supervision Selectors	5-4
5.1.9	LED Descriptions	5-4
5.2	SKE-ZN4 Specifications	5-4
5.3	Mounting the SKE-ZN4 In the SKE-450 Cabinet	5-5
5.4	Speaker Wiring	5-7
5.4.1	Wiring Procedure	5-7
5.4.2	Class B (Style Y)	5-7
5.4.3	Class A (Style Z)	5-8
5.4.4	FACP Alarm Zone Control Wiring	5-9
5.4.5	General Alarm Control Wiring	5-10

Section 6
SKE-ZN6 Six Zone Splitter Installation 8-1

6.1 SKE-ZN6 Board and Components 8-1

6.1.1 Terminal Strip 1 8-2

6.1.2 Terminal Strip 2 8-3

6.1.3 Terminal Strip 3 8-4

6.1.4 Manual Zone Switches 8-4

6.1.5 All Call Switch 8-4

6.1.6 LED Descriptions 8-4

6.2 SKE-ZN6 Specifications 8-5

6.3 Mounting the SKE-ZN6 In the SKE-450 Cabinet 8-5

6.4 Speaker Wiring 8-7

6.4.1 Wiring Procedure 8-7

6.4.2 Class B (Style Y) 8-8

6.4.3 Class A (Style Z) 8-8

6.4.4 FACP Alarm Zone Control Wiring 8-9

6.4.5 General Alarm Control Wiring 8-10

Section 7
SKE-SRM 9-1

7.1 Specifications 9-1

7.2 LED Description 9-2

7.3 Installation Instructions 9-2

7.3.1 Mounting the SKE-SRM Cabinet 9-2

7.3.2 Wiring Instructions 9-4

7.3.3 Remote Microphone Operation 9-5

Section 8
SKE-V70 Module Installation 10-1

8.1 Mounting 10-1

8.2 Speaker Wiring 10-3

8.2.1 Connecting the SKE-V70 to the Main Control Panel 10-3

8.2.2 Class B (Style Y) Wiring to the SKE-V70 10-4

8.2.3 Class A (Style Z) Wiring to the SKE-V70 10-4

8.2.4 Connecting the SKE-V70 to the SKE-ZN4 or -ZN6 10-5

Section 9

Battery Calculation 9-1

9.1 Calculating Current Draw and Standby Battery 9-1

Silent Knight Fire Product Warranty and Return Policy

Section 1

Overview

This manual contains information on how to install and operate the following voice evacuation controls:

Model Number	Consists of these Part Numbers	Where to find Additional Information
SKE-450	Main Control Panel	Section 3
SKE-450-ZN4	Main Control Panel	Section 3
	SKE-ZN4	Section 5
SKE-450-ZN6	Main Control Panel	Section 3
	SKE-ZN6	Section 6

1.1 Features

- 50 watt power output
- Built-in Digital Message Repeater (DMR)
- Two programmed 30 second messages, programmable to repeat 3, 4, 6, 8 or infinite number of times
- 8 pre-programmed tones
- 4 or 6 zone splitter (optional)
- LED indicators for:
 - Speaker Trouble (Yellow LED)
 - Alarm (Red LED)
 - Microphone Trouble (Yellow LED)
 - Command 2 Trouble (Yellow LED)
 - Earth Ground Fault (Yellow LED)
 - Low Battery (Yellow LED)
 - Power (Green LED)
- Form C Trouble Relay (Common)
- Form C AC Trouble Relay
- Supervised and activated by host fire control system
- Auxiliary audio input
- Supervised Remote Microphone input (Special application for optional SKE-SRM)
- Class A or B speaker supervision
- DIP switch programmable
- UL 864 & 1711 Listed

1.2 Optional Accessories

Part Number	Description
SKE-ZN4	4 Zone Audio Splitter (see Section 5 for more information)
SKE-SRM	Supervised Remote Microphone (see Section 7 for details)
SKE-ZN6	6 Zone Audio Splitter (see Section 6 for more information)
SKE-V70	Converts the speaker circuit voltage from 25 to 70.7 Vrms (see Section 8 for more information)

1.3 About This Manual

This manual is intended to be a complete reference for all installation and operation tasks. Please let us know if the manual does not meet your needs in any way. We value your feedback!

1.4 How to Contact Silent Knight

If you have a question or encounter a problem not covered in this manual, contact Silent Knight Technical Support at 800-446-6444.

To order parts, contact Silent Knight Sales at 800-328-0103 (or 203-484-7161).

Section 2

Agency Listings, Approvals, and Requirements

2.1 FCC Warning

This device has been verified to comply with FCC Rules Part 15. Operation is subject to the two following conditions: (1) This device may not cause radio interference, and (2) this device must accept any interference received, including interference that may cause undesired operation.

2.2 Underwriters Laboratories (UL)

The SKE-450 is UL listed as a voice evacuation unit for use in NFPA 72 systems. If the SKE-450 and its accessories are to be used as part of a UL installation, carefully read the UL requirements in this section. For more information on NFPA 72 standards, refer to the *NFPA National Fire Alarm Code*.

2.2.1 Requirements for All Installations

General requirements are described in this section. When installing an individual device, refer to the specific section of the manual for additional requirements.

1. All field wiring must be installed in accordance with NFPA 70, National Electric Code.
2. Use UL listed notification devices with the SKE-450 voice evacuation system.
3. A full system checkout must be performed any time the panel is programmed.
4. UL installations using Class B wiring for the speaker circuit require the use of a Model 7630 EOL resistor assembly.

2.2.2 Requirements for Local Protected Fire Alarm Systems

At least one UL-listed, supervised notification appliance must be used.

This page left blank intentionally.

Section 3

Installation

This section of the manual is intended to help you plan your tasks to facilitate the installation. Please read this section thoroughly, especially if you are installing a SKE-450 control for the first time.

3.1 Environmental Specifications

It is important to protect the SKE-450 control panel from moisture. To prevent damage, the following conditions should be avoided when installing the units:

- Mount indoors in dry locations only
- Do not mount directly on exterior walls, especially masonry walls (condensation)
- Do not mount directly on exterior walls below grade (condensation)
- Protect from plumbing leaks
- Protect from splash caused by sprinkler inspection ports
- Do not mount in areas with humidity-generating equipment (such as dryers, production machinery)

When selecting a location to mount the panel, it should be mounted where it will NOT be exposed to temperatures outside the range of 0°C-49°C (32°F-120°F) or humidity equal to or greater than 93% at 30°C (89°F) noncondensing.

3.2 Electrical Specification

Table 3-1: Electrical Specifications

Circuit	Rating
Operating Voltage	120 Vrms @ 60 Hz @ 1.2 amp *230 Vrms @ 50Hz @ .607 amp
Battery Charging Voltage/Circuit	27.4 VDC @ 1.9A max/ 0.75 avg
Trouble Relays	2.5 A @ 30 VDC resistive
Minimum Low AC Detect	92VAC 25V System 94VAC 70.7V System

* Specify voltage requirements when ordering.

Note: Refer to the control panel wiring diagram to determine which power source is required for your control.

3.3 Board Layout

This section of the manual describes the components of the control panel that may be used by the installer or operator.

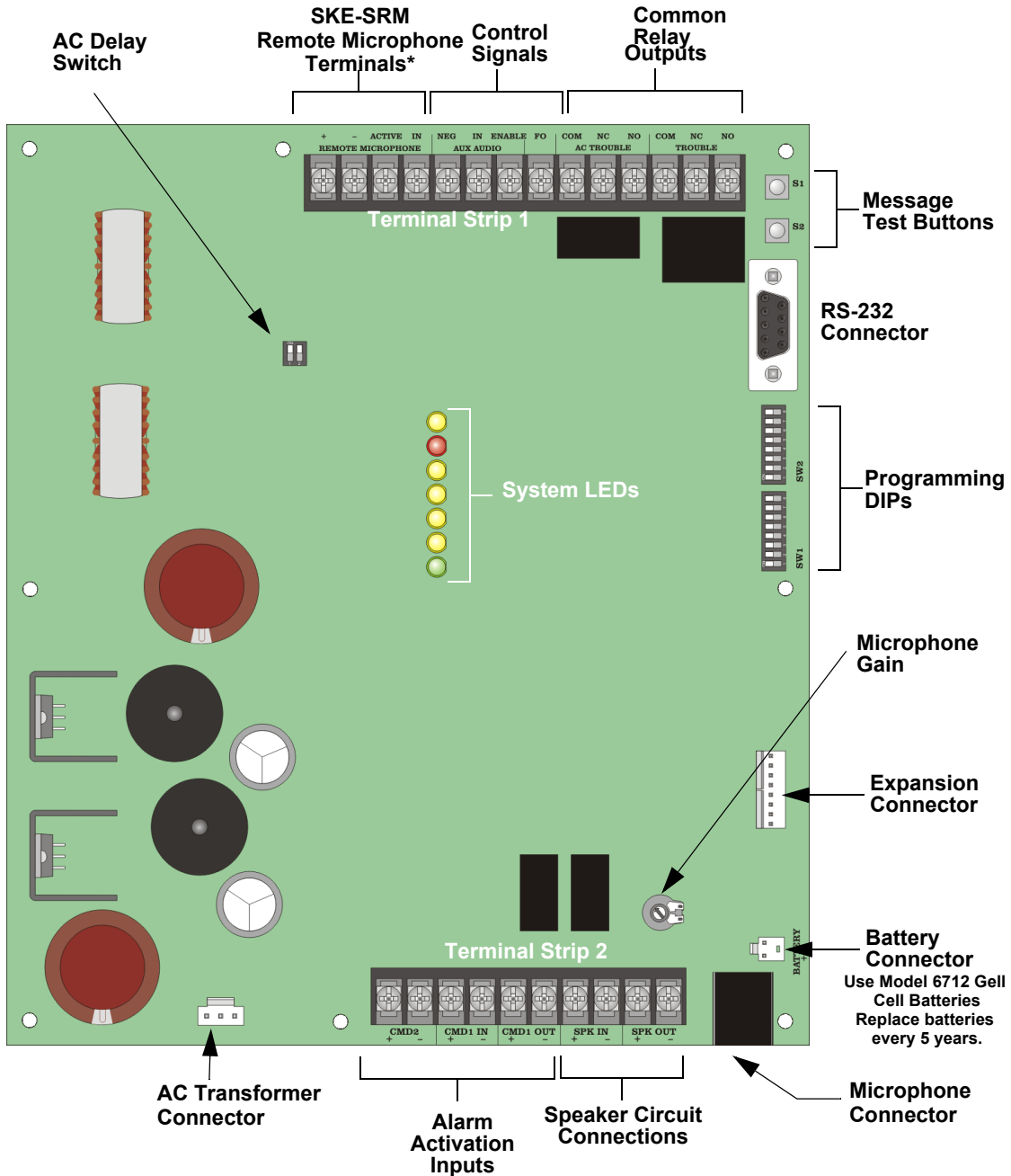

* Special Applications

Figure 3-1 Board Layout

3.3.1 Wiring Overview

Figure 3-2 provides a basic wiring overview. Refer to the appropriate section in the manual for more information.

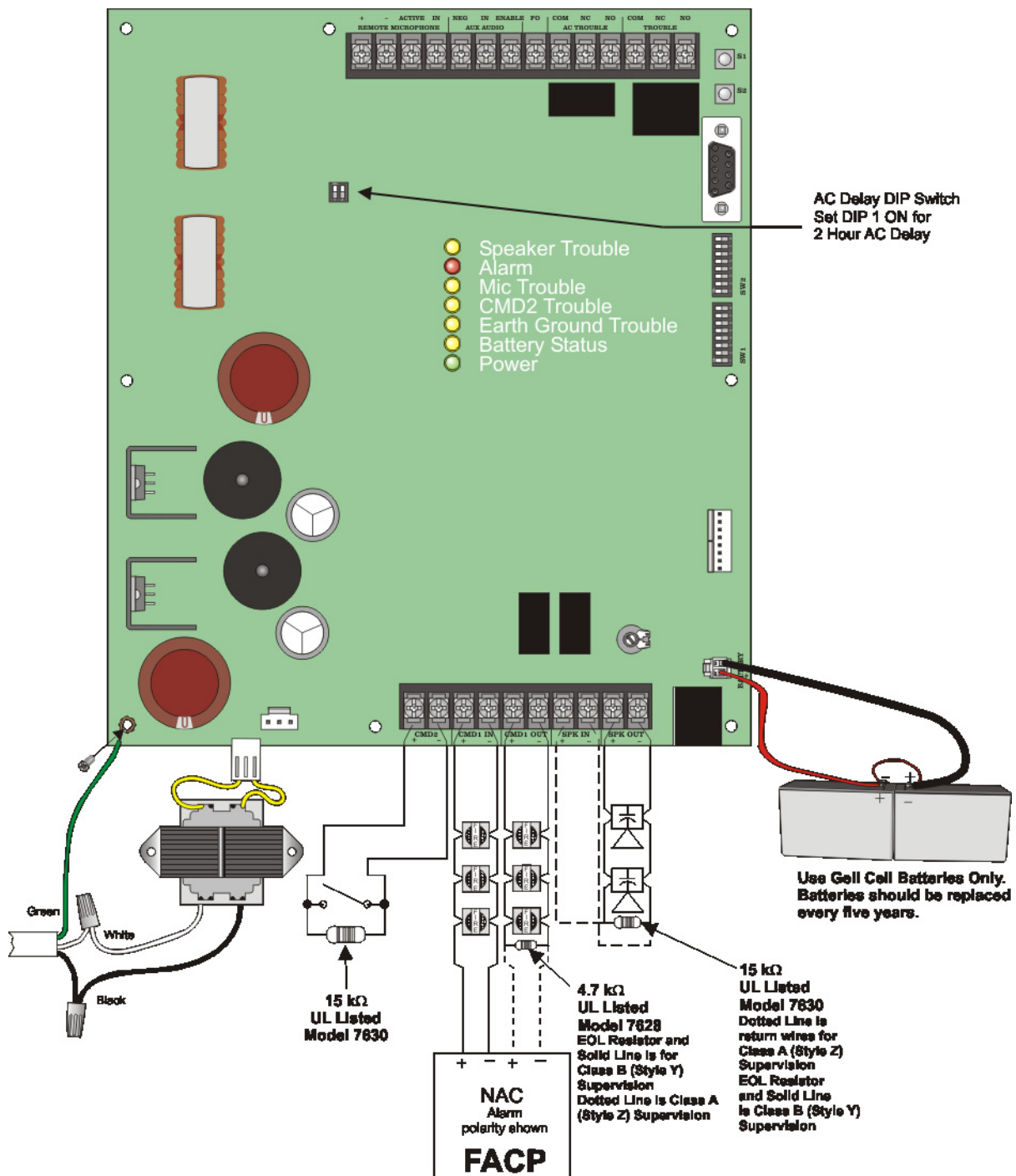

Figure 3-2 SKE-450 Wiring Overview

3.3.2 Terminal Strip 1

Table 3-2: Terminal Strip 1 Description

Terminal Name		Comments
+	Remote Microphone	See Section 7.3.2 for details.
-		
Active		
IN		
Neg	Aux Audio (Input)	For recording custom message only. See Section 4.2.2.
In		
Enable		
FO		Not Used
Com	AC Trouble (Relay)	Form C energizes when an AC trouble is detected regardless of setting of the AC delay switch.
NC		
NO		
Com	Trouble (Relay)	Form C common trouble relay
NC		
NO		

3.3.3 Terminal Strip 2

Table 3-3: Terminal Strip 2 Description

Terminal Name		Comments
+	CMD2 IN	A short across this input will activate message 2.
-		
+	CMD1 IN	A reverse polarity trip from the FACP will activate message 1.
-		
+	CMD1 OUT	
-		
+	SPK IN	Used for Class A (Style Z) speaker connections
-		
+	SPK OUT	Used for Class B (Style Y) and Class A (Style Z) speaker connections.
-		

3.3.4 Earth Fault Resistance

Table 3-4 lists the earth fault resistance detection for each applicable terminal on the control panel.

Table 3-4: Earth Fault Resistance Values by Terminal

Terminal Name		Value (in kohms)
+	Remote Microphone	0
-		0
Active		0
IN		0
+	CMD2 IN	0
-		0
+	SPK IN	0
-		0
+	SPK OUT	0
-		0

3.3.5 System LEDs

The control panel has LEDs which indicate system operation, alarms, and trouble conditions. Table 3-5 lists the LEDs and their function. See also .

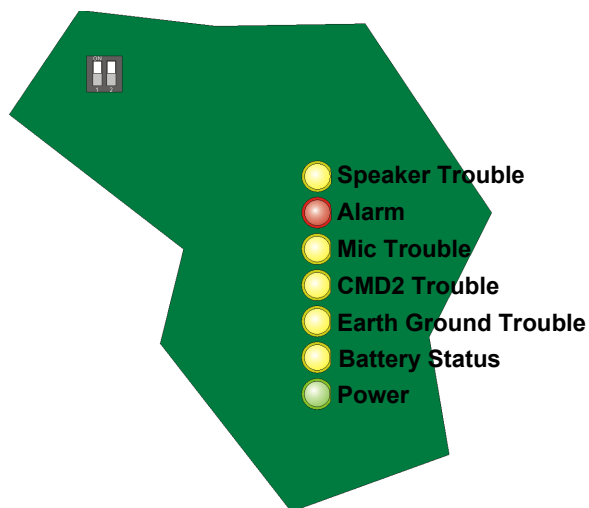

Figure 3-3 System LEDs Close-up View

Table 3-5: LED Descriptions

LED Name	Color	Description	Comments
Speaker Trouble	Yellow	ON = Speaker circuit trouble OFF = Speaker/amp is operating normally	Trouble relay energized.
Alarm	Red	ON = Alarm OFF = No alarms	Either CMD1 and/or CMD2 are activated.
Mic Trouble	Yellow	ON = Trouble with on-board microphone OFF = Microphone connected Flashing = Trouble with remote microphone	Trouble relay energized.
CMD2 Trouble	Yellow	ON = Trouble condition with CMD2 input, EOL trouble OFF = CMD2 operating properly	Trouble relay energized.
Earth Ground	Yellow	ON = Earth Ground Fault detected OFF = No Earth Ground Fault detected	Trouble relay energized.
Battery Status	Yellow	ON = Low Battery OFF = Battery OK	Trouble relay energized.
Power	Green	ON (Steady) = Power is present Flashing = No AC power to the control.	Trouble relay energized immediately on trouble unless AC Delay is enabled, in which case, trouble relay will energize in 2 hours.

3.3.6 Microphone Connection

The microphone connector is used to connect a hand held microphone into the system. The microphone can be used to record a message and as a manual voice evacuation override. See Figure 3-4.

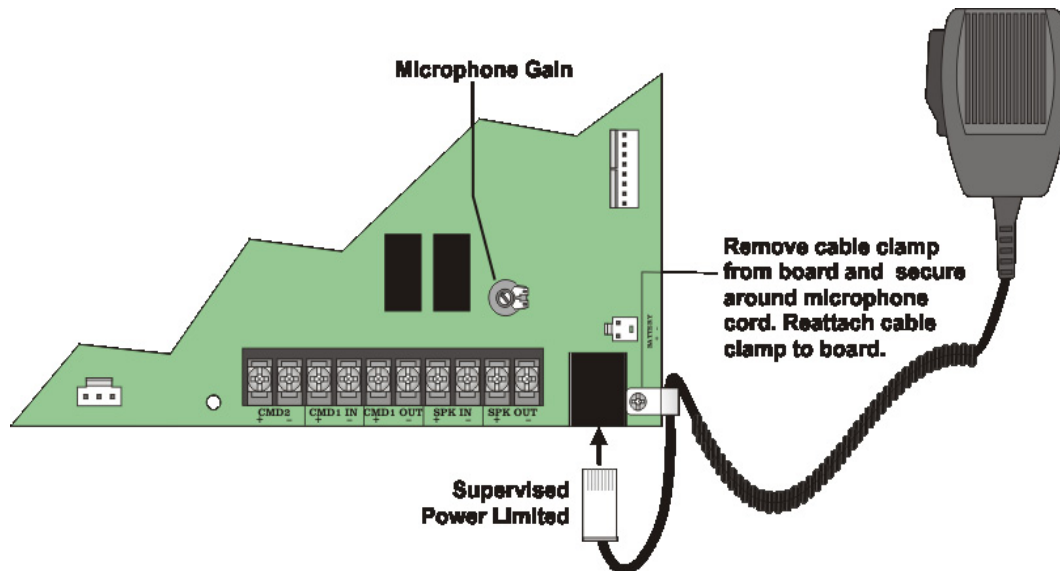

Figure 3-4 Microphone Connection

3.3.7 RS-232 Serial Connector

The RS-232 serial connector is used to directly connect the main control to a PC or laptop to up/download custom system messages. See Section 4.2.2.2.

3.3.8 Microphone (MIC) Gain

Turn fully clockwise for maximum gain, turn fully counter-clockwise for minimum gain. See Figure 3-4 for Microphone Gain control location.

3.3.9 S1 & S2 Message Test Buttons

In normal operating mode you can test CMD 1 and CMD 2 messages by pressing the S1 button (for CMD 1 message) or S2 button (for CMD 2 message). When the S1 or S2 button is pressed for 1 second, the audio message and notification output will begin sounding, simulating an actual CMD input alarm. The message and notification will continue to sound (as programmed) for ten minutes, or you can manually silence them by pressing the same CMD button for 1 second. See Section 4.2 for S1 and S2 functions in recording mode.

3.3.10 AC Delay Switch

The SKE-450 has two built-in trouble relays – General Trouble and AC Trouble.

The General trouble relay will energize when any trouble condition is detected. If the only trouble condition is an AC failure, the relay output can be programmed to delay the indication by 2 hours by setting the DIP AC Delay Switch 1 to ON. If the AC Delay Switch is in the OFF position the trouble relay will energize immediately when AC power fails. See Figure 3-1 for AC Delay Switch location. The AC Delay Switch may be used only when the SKE-450 is connected to an FACP that uses central station or off premise signaling.

The AC trouble relay will energize when an AC trouble is detected regardless of the settings of the AC delay switch.

3.4 Mounting the Control Panel

Read the environmental specifications in Section 3.1 before mounting the control panel cabinet. This will ensure that you select a suitable mounting location.

The panel should be accessible to main drop wiring runs. It should be mounted as close to the center of the building as possible and located within a secured area, but should be accessible for testing and service.

Mount the control panel cabinet so it is firmly secured to the wall surface. When mounting on concrete, especially when moisture is expected, attach a piece of 3/4-inch plywood to the concrete surface and then attach the cabinet to the plywood. Also mount any other modules to the plywood.

The cabinet can be surface or flush-mounted. If you will be flush-mounting the cabinet, the hole for the enclosure should be 14.5" W x 24.75" H x 3-7/16" D (36.8cm W x 62.9cm H x 8.73cm D). Do not flush-mount in a wall designated as a fire break.

3.4.1 Preventing Water Damage

Water damage to the fire system can be caused by moisture entering the cabinet through the conduits. Conduits that are installed to enter the top of the cabinet are most likely to cause water problems. Installers should take reasonable precautions to prevent water from entering the cabinet. Water damage is not covered under warranty.

3.4.2 Wiring Specifications

The maximum line resistance of the wire run from FACP to voice evacuation control system is 50W. All wiring and devices installed in the system must meet the standards described in National Electrical Code (NFPA 70), NFPA Standard 72, and Life Safety Code (NFPA 101).

To avoid induced noise (transfer of electrical energy from one wire to another), keep input wiring isolated from high-current output and power wiring. Avoid pulling one multiconductor cable for the entire panel. Instead, separate the wiring as follows:

Table 3-6

1/4" spacing must be maintained between each of these circuit types; as well as between power limited and non power-limited circuits.	Input/Output Type	Wiring
	Non Power-Limited:	AC power, Standby batteries
	Power-Limited:	Notification devices, SKE-SRM, and Relays
	Audio:	Speaker

DO NOT pull wires from different groups through the same conduit.

For the same reasons, wiring within the cabinet should be routed around the perimeter of the cabinet. It should not cross the printed circuit board where it could induce noise into the sensitive microelectronics or pick up unwanted RF noise from the high speed circuits.

High frequency noise, such as that produced by the inductive reactance of a speaker or bell, can also be reduced by running the wire through ferrite beads or by wrapping it around a ferrite toroid core. Figure 3-5 provides an example.

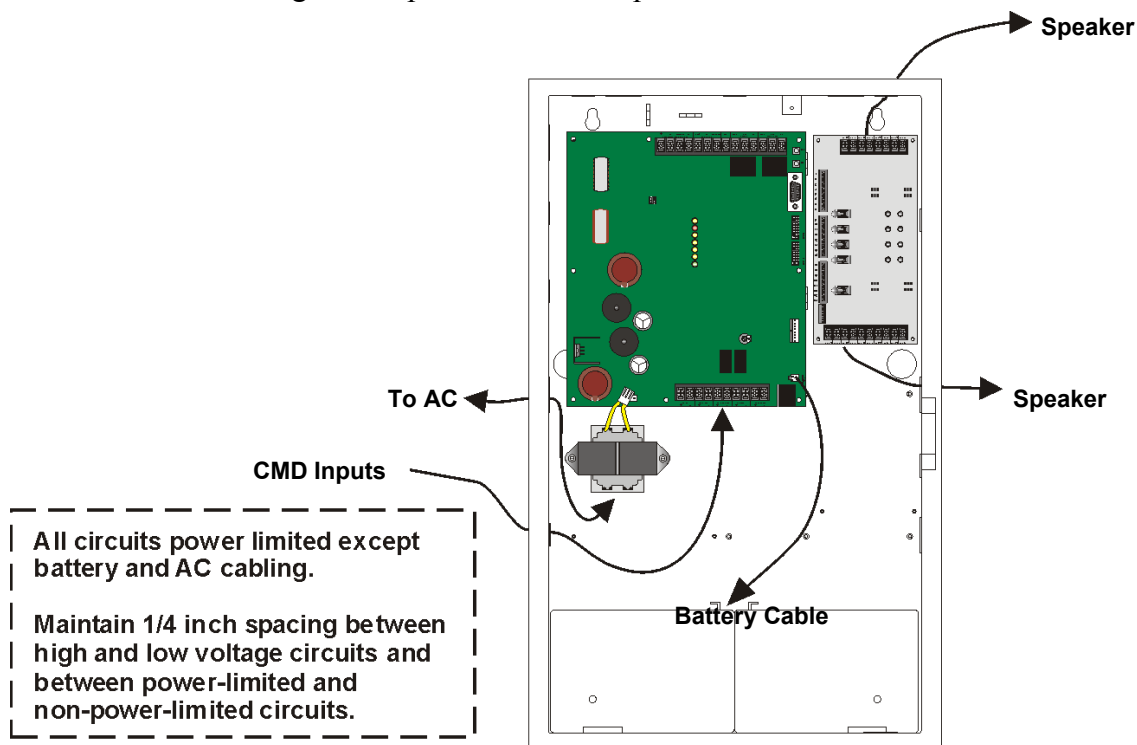

Figure 3-5 Wire Routing Example

3.5 Mounting the Main Control Board in the Cabinet

Follow these steps to properly install the main control board into the cabinet:

1. Unlock and open the cabinet door.
2. Remove the two cover plate retaining screws, then open the control panel cover plate. See Figure 3-6.

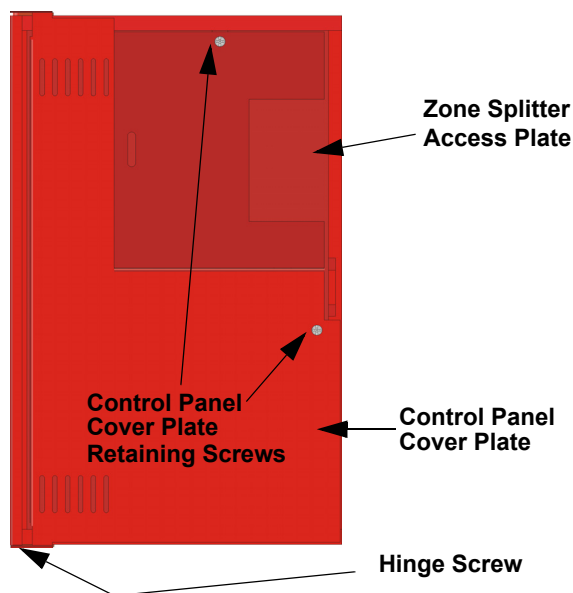

Figure 3-6 View of Cabinet With Cover Plate in Place

Note: The control panel cover plate can be remove by removing the Hinge screw.

3. Run all wire needed to install the system at this time. See Sections 3.6 and 3.7.
4. Mount the main control board into the cabinet as shown in Figure 3-7.

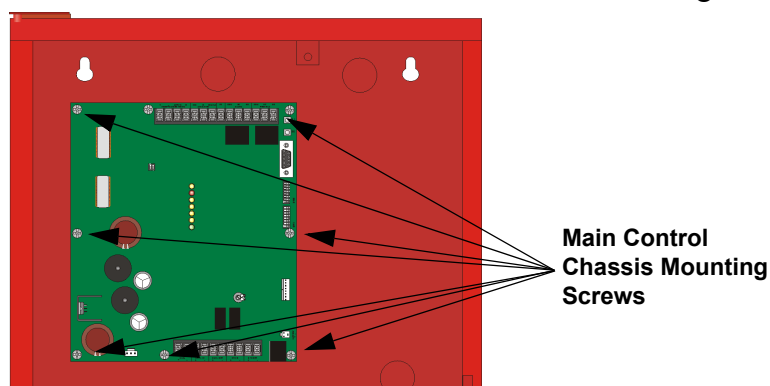

Figure 3-7 Main Control Board Mounting Location

5. Connect wiring as described in Sections 3.6, 3.7, and 3.8.

3.6 Speaker Wiring

Each SKE-450 supplies one NAC (Notification Appliance Circuit) for speaker connection. The speaker circuit can be supervised and wired Class B (Style Y) or Class A (Style Z). The speaker circuit is capable of 50 watts of power at 25 Vrms or 70.7 Vrms (using the SKE-V70 Module, see Section 8 for SKE-V70 installing instructions).

Note: If the SKE-V70 Module is installed, all speaker wiring must be separated by a minimum of 1/4" from the low voltage wiring, and must exit the cabinet through its own opening.

3.6.1 Wiring Lengths

Table 3-7

Number Of Speakers		Total Load		Wire Distance in Feet			
@1/2 W	@1 W	Vrms	Watts	18 AWG	16 AWG	14 AWG	12 AWG
10	5	25Vrms	5W	3900	6200	9860	15680
		70Vrms		25000	39700	63200	100520
20	10	25Vrms	10W	2125	3380	5375	8540
		70Vrms		15200	24150	38400	61100
30	15	25Vrms	15W	1460	2320	3690	5870
		70Vrms		11000	17500	27800	44200
40	20	25Vrms	20W	1100	1750	2780	4420
		70Vrms		8500	13510	21500	34175
52	26	25Vrms	26W	760	1200	1920	3050
		70Vrms		6100	9700	15400	24520
80	40	25Vrms	40W	550	875	1390	2200
		70Vrms		4100	6500	10360	16480
100	50	25Vrms	50W	450	715	1130	1800
		70Vrms		3500	5560	8850	14070

Note: The above table assumes a uniform distribution of the speakers, and that a max of 20% voltage drop on the last speaker is allowed.

3.6.2 Class B (Style Y)

Figure 3-8 illustrates how to wire speakers to the control panel using Class B (Style Y) supervision.

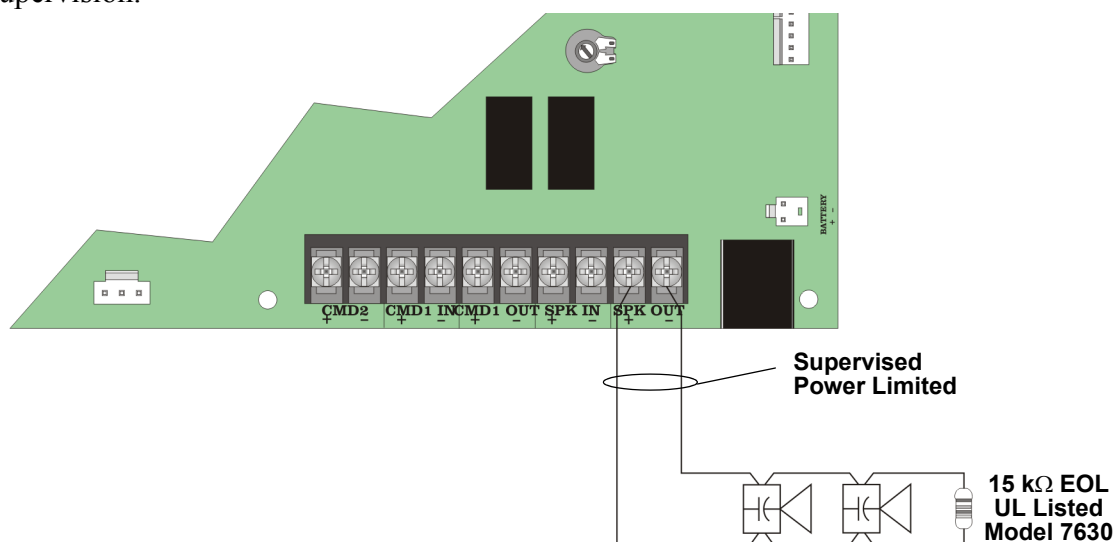

Figure 3-8 Class B (Style Y) Speaker Configuration

3.6.3 Class A (Style Z)

Figure 3-9 illustrates how to wire speakers to the control panel using Class A (Style Z) wiring.

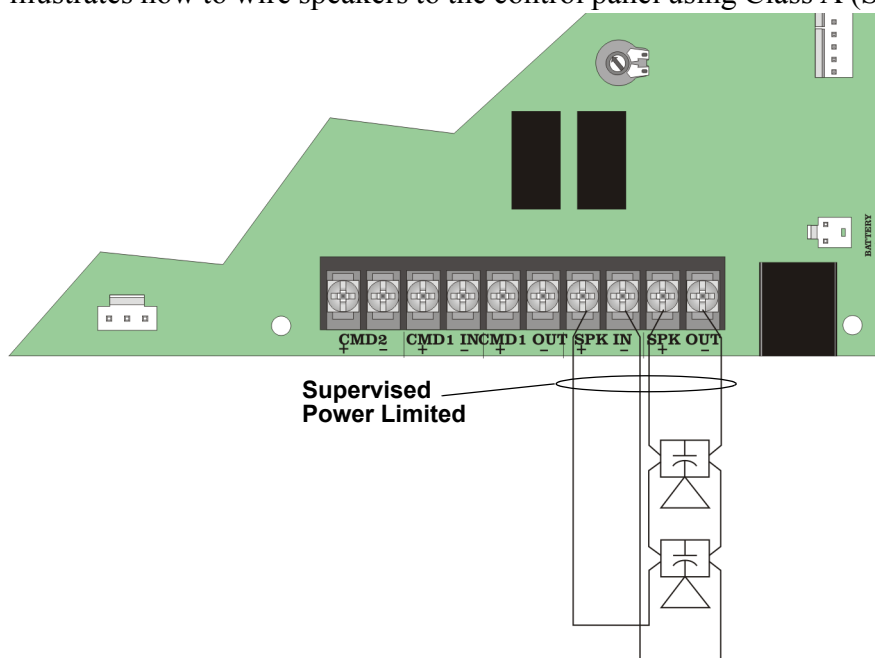

Figure 3-9 Class A (Style Z) Speaker Configuration

3.7 Input Circuits

The SKE-450 has two command input circuits (CMD1 & CMD2). The command input circuits are used to activate the amplifier that transmits the audio signal over the output speakers.

3.7.1 CMD1 Input Circuit

This section describes how to connect Class B (Style Y) or Class A (Style Z) inputs to CMD1 terminals. CMD1 input circuit rating is 12 to 30 VDC @ 50 mA. CMD1 is a polarity reverse input to activate and supervise the SKE-450

3.7.1.1 Class B (Style Y)

Figure 3-10 illustrates how to wire a Class B (Style Y) input circuit to CMD1 input.

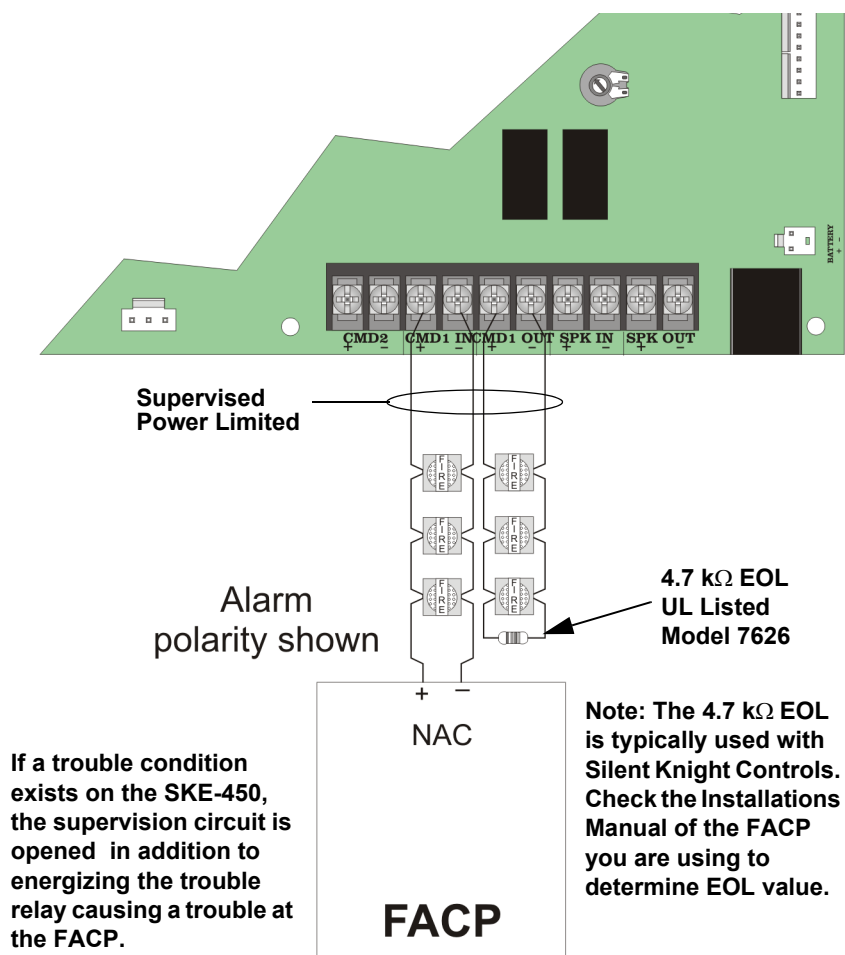

Figure 3-10 Class B (Style Y) CMD1 Input Circuit Configuration

3.7.1.2 Class A (Style Z)

Figure 3-11 illustrates how to wire a Class A (Style Z) input circuit to CMD1 input.

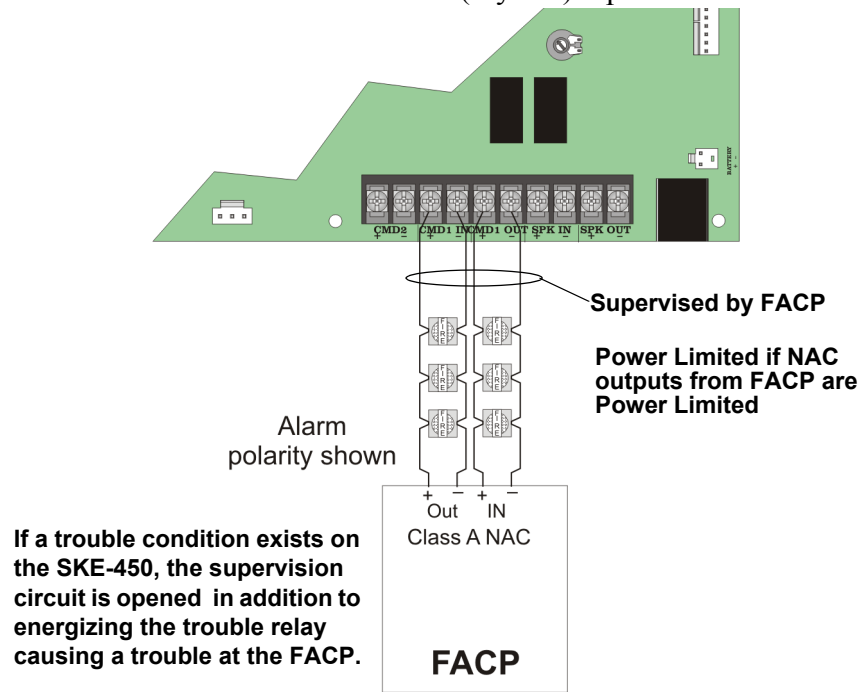
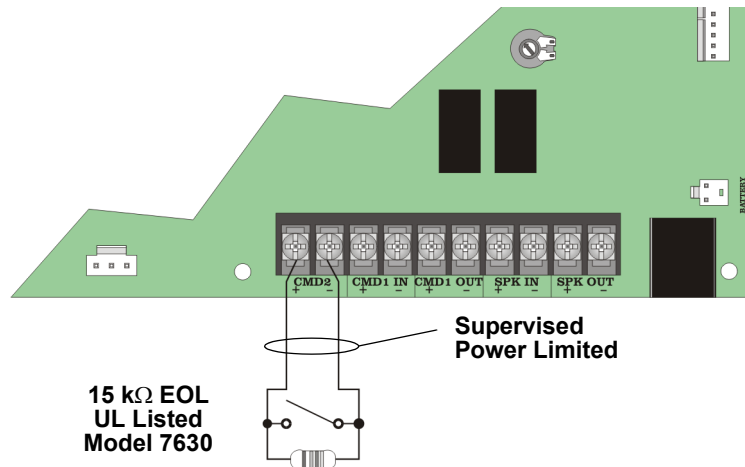

Figure 3-11 Class A (Style Z) CMD1 Input Circuit Configuration

3.7.2 CMD2 Input Circuit

This section describes how to connect a normally open alarm contact, such as a pull station, to the CMD2 terminals on the SKE-450. See Figure 3-12. CMD 2 input rated for 24 VDC @ 3 mA.



If a trouble condition exists on the SKE-450, the trouble relay will energize, which is used by the FACP.

Figure 3-12 CMD2 Alarm Contact Input Connections

3.8 Connecting Power

3.8.1 AC Power

The following instruction provide the a step-by-step procedure for installing the AC transformer and how to connect the AC power.

Follow these steps to install the AC transformer:

1. Open Cabinet door.
2. To access cabinet interior, open dead-front panel by removing the upper screw and the mid-door retaining nut. See Figure 3-6.
3. Mount the transformer onto the cabinet standoffs with the supplied #6 nuts as shown in Figure 3-13.

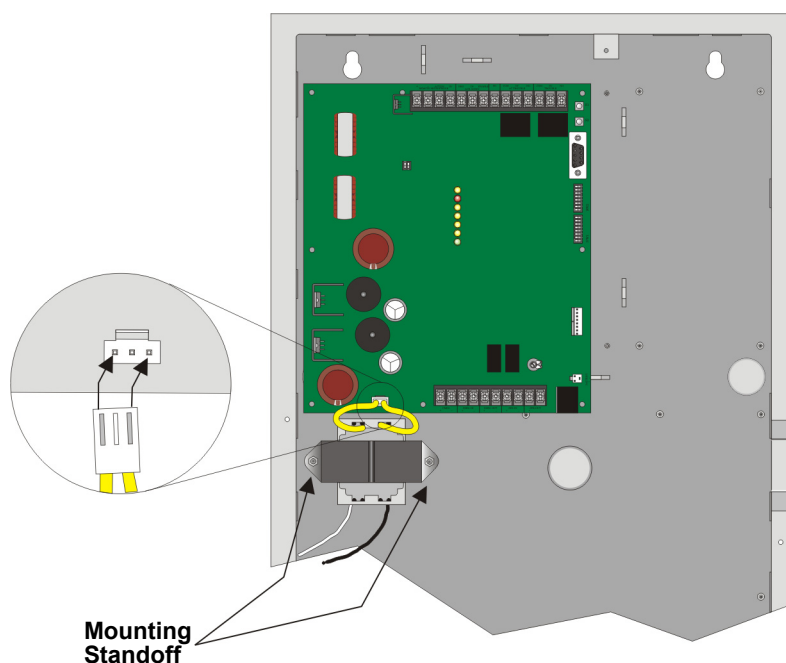

Figure 3-13 Transformer Mounting

4. Wire AC to the transformer as shown in Figure 3-14.

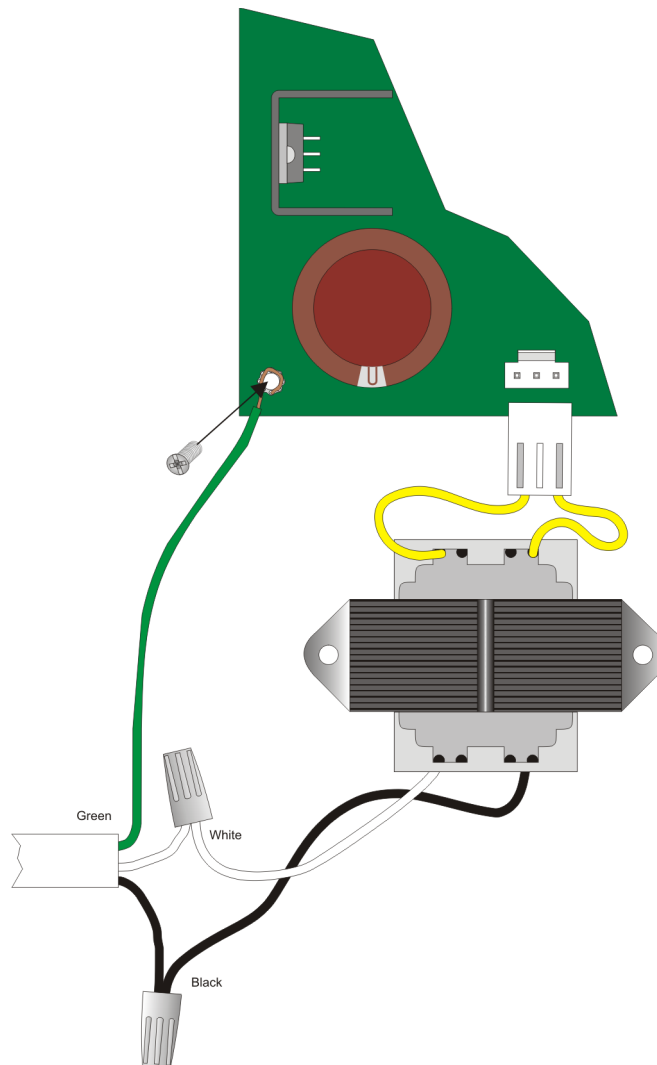

Figure 3-14 AC Connections

5. Plug the transformer output to the AC connector on the control panel as shown in Figure 3-13.

3.8.2 Backup Battery Power

The following steps explain how to connect the batteries (refer to Figure 3-15):

1. Connect the black wire to the negative (-) side of the battery #2.
2. Connect the jumper wire provided from the positive (+) side of battery #2 to the negative side of battery #1.
3. Connect the red wire to the positive (+) side of battery #1.

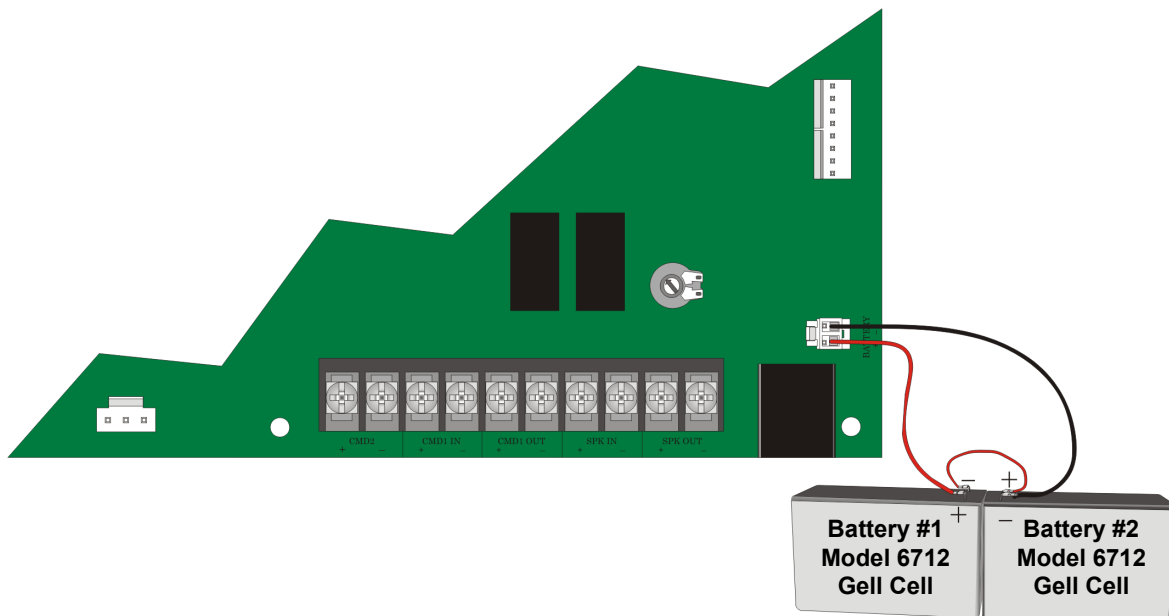

Replace batteries every 5 years.

Figure 3-15 Battery Connection

This page left blank intentionally.

Section 4

Programming

This section of the manual describes how to program the SKE-450 using the programming DIP switches.

4.1 DIP Switch Programming

Table 4-1 lists the programming DIP switches, and describes what each of their settings accomplish.

Table 4-1: DIP Switch Programming

DIP Switch	Function	Switch Number								Setting	Comments	
		1	2	3	4	5	6	7	8			
SW1	Initial Message Delay	off	off	off							0 Seconds	This option selects the initial delay before the message starts playing after an alarm. The tone sounds during the delay.
		on	off	off							4 Seconds	
		off	on	off							8 Seconds	
		on	on	off							12 Seconds	
		off	off	on							16 Seconds	
		on	off	on							20 Seconds	
		off	on	on							24 Seconds	
		on	on	on							28 seconds	For UL 864 installations, this option must be set to a minimum of 8 seconds.
	Delay Between Messages				off	off					4 Seconds	
					on	off					8 Seconds	
					off	on					12 Seconds	
					on	on					16 Seconds	
	Message Repeat						off	off	off		None	This option selects the total number of times that the message will be repeated. For UL 864 installations, this option must be set to a minimum of 3.
							on	off	off		1	
							off	on	off		2	
							on	on	off		3	
							off	off	on		4	
							on	off	on		5	
							off	on	on		6	
						on	on	on		Continuously		

Table 4-1: DIP Switch Programming

DIP Switch	Function	Switch Number								Setting	Comments	
		1	2	3	4	5	6	7	8			
SW2	Evacuation Tone Pattern	off	off	off							ANSI Cadence	This option selects the tone sound that will be made during evacuation. For UL 864 installations, this option must be set to ANSI cadence.
		on	off	off							March Code	
		off	on	off							California	
		on	on	off							Steady	
		off	off	on							Alert Tone	
		on	off	on							Hi-Lo	
		off	on	on							ANSI Whoop	
		on	on	on							Continuous Whoop	
	Local Mic. Supervision Selection				off						Not supervised	This selection determines if the local microphone will be supervised. For UL 864 installations, this option must be set to ON. OFF is not acceptable for UL 864 installations.
					on						Supervised	
	Remote Mic					off					Not supervised	This selection determines if the remote microphone will be supervised. For UL 864 installations, this option must be set to ON. OFF is not acceptable for UL 864 installations.
						on					Supervised	
	CMD1 uses recorded message							off			Play Pre-recorded CMD1 message	This option selects which message will be played for CMD1 or CMD2, either the pre-recorded or the recorded message.
								on			Play Recorded Message	
	CMD2 uses recorded message								off		Play Pre-recorded CMD2 message	
									on		Play Recorded Message	
	Enter Record Mode									off		
										on		

4.2 Recording Custom Message

The SKE-450 comes with three recorded messages (see Table 4-2). Message 1 & 2 can be changed through the 7780 software; Message 3 can be recorded from the microphone or by using the 7780 software. Message 1 & 2 are 32 seconds long, and Message 3 is 49 seconds long.

Table 4-2: Preprogrammed Messages

Message No.	Voice Gender	Message
Message 1	Female	ATTENTION PLEASE. There has been a report of an emergency. Proceed calmly to the nearest exit and leave the building immediately. Do not use the elevators. Use stairwells where necessary. All handicapped occupants shall use the building's evacuation plan.
Message 2	Male	We have a fire alarm in our building. Please stay in your apartment and keep your apartment doors closed; Keep your windows shut and leave all fire doors closed. Do not use the elevators, and stand by for further instructions.
Message 3	Female	ATTENTION PLEASE. The signal tone you have just heard indicates a report of an event in the building. Please await further instructions while the report is being verified. If further action is necessary, you will be instructed to follow floor response plans.

When in the record mode, the Speaker Trouble and Mic Trouble LEDs will function as follows:

Table 4-3

LED	LED Appearance	Meaning
Speaker Trouble	Solid ON	Erasing user message.
	FLASHING	Recording user message.
	OFF	Normal mode (not recording)
Mic Trouble	ON	Flash is programmed with user message.
	OFF	Flash is erased.
	FLASHING	Flash error, need to erase and re-record.

While in record mode, the Message Test Buttons are used as follows:

S1: Replay the recorded message. Message will continue to repeat until the S1 button is pressed again.

S2: Used to erase message 3. To erase the user message, press S2 until the Speaker Trouble LED turns on. When the Speaker Trouble LED turns off again, the message will be fully erased.

4.2.1 Input Message 3 From the Microphone

This section contains information on how to record and erase message 3 from the control panel.

4.2.1.1 Record Message 3 Using the Microphone

Follow these steps to record message 3 using the microphone:

1. Place DIP switch number 8 of SW2 to the “On” position.

The trouble relay will energize.

Important! *When the SKE-450 is in Record Mode, the trouble relay will energize and CMD1 relay will be open. Alarms will not be detected while the system is in Record Mode.*

2. Press in the microphone switch and speak the desired message (49 seconds maximum).

While your message is being recorded, the Speaker Trouble LED will flash. Once the microphone switch is released, the Mic Trouble LED will Light.

If there is an error in the flash memory while recording, the Mic Trouble LED will flash. Then erase the message, and record message again.

Note: Once a message is recorded, a new message can not be recorded over it until the previous message is erased.

3. When you have completed recording message 3, return DIP switch number 8 of SW2 to the “Off” position.

4.2.1.2 To Erase Message 3

Follow these steps to erase message 3:

1. Place DIP switch number 8 of SW2 to the “On” position.

The trouble relay will energize.

2. Press and hold Message Test Button S2 until the Speaker Trouble LED lights.

3. If you wish to record a new message, follow the steps listed in Section 4.2.1.1.

OR

4. Return DIP switch number 8 of SW2 to the “Off” position.

4.2.2 Input Message 3 From a PC

There are two ways to input message 3 into the system using a PC or laptop computer. Message 3 can be recorded from the audio output of a PC sound card, or through the serial port using the 7780 software.

4.2.2.1 Using the Aux Audio input

Message 3 can be recorded from the “Line Out” on the sound card of a PC or Laptop.

To input a message through the Aux Audio terminals on the SKE-450:

1. Wire a speaker cable with 1/8” mini plug (Radio Shack Cat. No. 42-2454) to Aux Audio Neg and IN terminals. Refer to Figure 4-1.

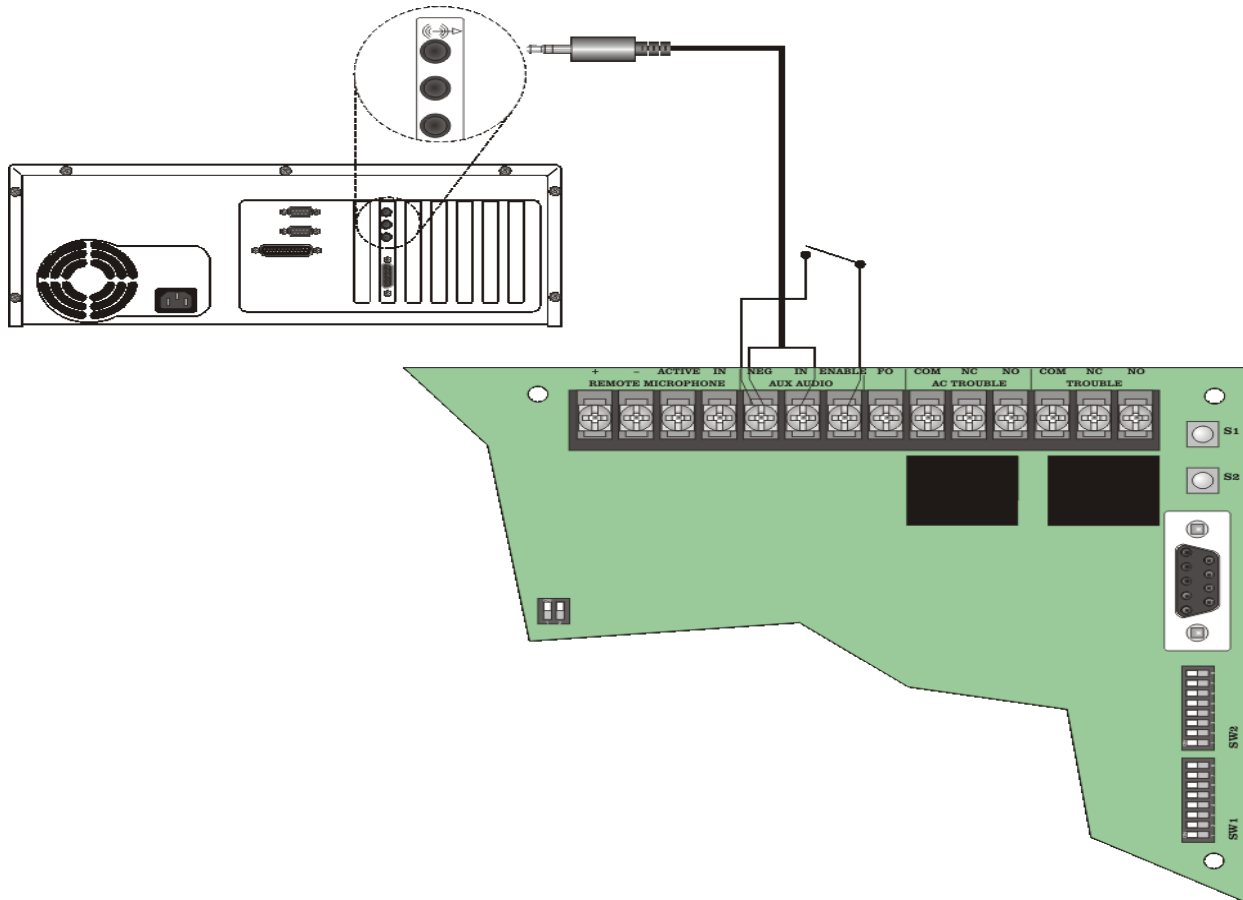

Figure 4-1 Aux Audio Connection for Recording

2. Plug a the mini plug into the Line Out/Headphone jack on a PC or Laptop. See Figure 4-1.
3. Wire a switch between Aux Audio Enable and NEG. See Figure 4-1.
4. Place DIP switch number 8 of SW2 to the “On” position.
The trouble relay will energize.
5. Close the switch connected between Enable and NEG.
6. From the PC, play the desired audio file (such as a wave file). Maximum length of audio file is 49 seconds.
7. When audio file is complete, open the switch between Enable and NEG.
8. Remove the mini plug assembly from the control board.
9. Return DIP switch number 8 of SW2 to the “Off” position.

4.2.2.2 Using 7780 Software

The 7780 software is a software support utility that is used to download recorded messages (in .ske format stored on your PC hard drive) to the various message locations of the SKE-450. Messages can be uploaded from the SKE-450, stored, and used again in similar installations. The 7780 software can also be used to move messages to different message locations. For example, move message 1 to message 3 memory location.

To read/write .SKE formatted messages to and from the SKE-450 main panel, follow these steps:

1. Make sure that panel is in Normal mode. This is accomplished by setting DIP switch number 8 on SW 2 to the “Off” position, and recycling power.
2. Connect the PC to the panel using a standard 9-pin serial cable. See Figure 4-2.

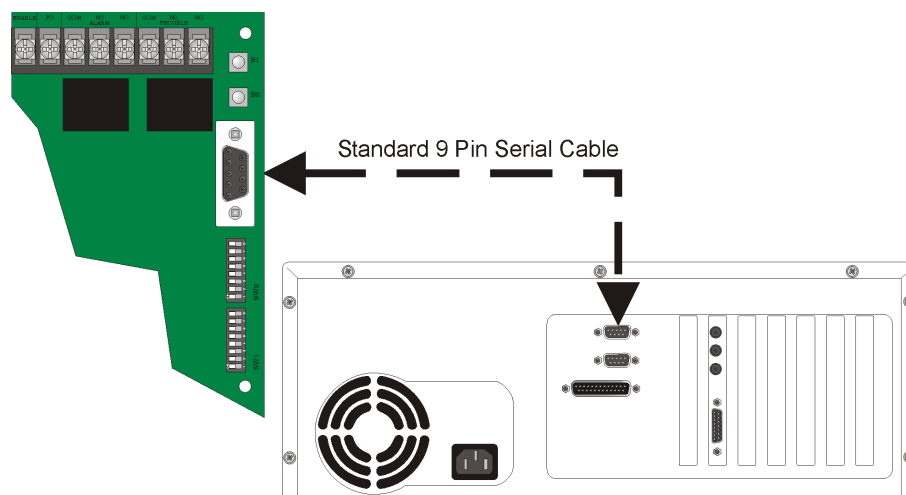

Figure 4-2 Serial Cable Connections

3. Run the 7780 software.
4. Select the appropriate COM port that you are using.
5. Press the "Capture Panel" button. (A capture dialog will appear on the screen.)
6. Set DIP switch number 8 on SW2 to the “ON” position.
7. The "Capture" dialog should disappear after the PC-panel connection is established.
8. Select "Read from Panel" to read a message and store onto your hard drive, or "Write to Panel" to transfer a .SKE formatted message to the panel.
9. Select the appropriate message location you wish to read/write.
10. Enter the file name you wish to transfer (Press "Browse" to display a list of files.)
11. Press "Start" to start the transfer.
12. When transfer is completed, press "Release Panel".
13. Set DIP switch number 8 on SW2 to “OFF” to return the panel to "Normal Mode".
14. Remove 9-pin serial cable.

Section 5

SKE-ZN4 Zone Splitter

This section contains information on how to install the SKE-ZN4 Zone Splitter into the SKE-450 cabinet, and how to connect input and output devices to the zone splitter.

A zone splitter is a device that can split the audio output from the main amp into separate audio output channels. The SKE-ZN4 is capable of splitting the audio to four separate zones or channels.

The SKE-ZN4 can be used in installations where the audio must be split to different floors or zones to accommodate a safe and efficient evacuation process.

Important: See Section 5.4.4 and 5.4.5 for output control of speaker circuits by zone or general alarm.

5.1 SKE-ZN4 Board and Components

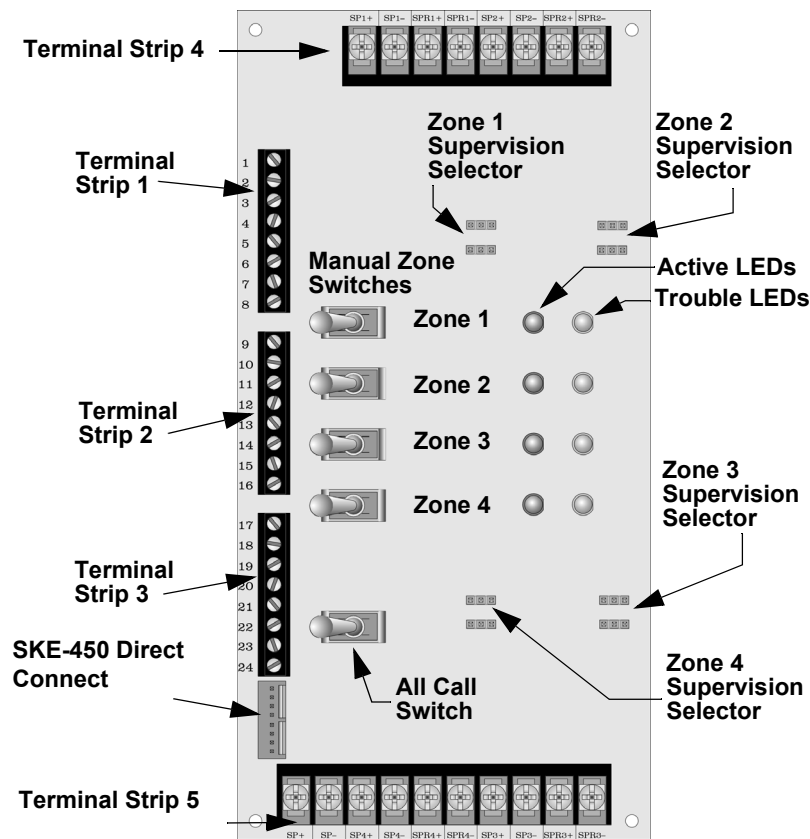

Figure 5-1 SKE-ZN4 Board Components

5.1.1 Terminal Strip 1

This section describes what the terminal connections of terminal strip 1 are used for.

Terminal Number	Name	Description
1	+24 VDC	Positive 24 VDC in or out.
2	GND	Ground
3		
4		Not Used
5		
6		
7		
8	GND	Ground

5.1.2 Terminal Strip 2

This section describes what the terminal connections of terminal strip 2 are used for.

Terminal Number	Name	Description
9	GND	Ground
10	Alarm Active	Signal input from main DMR to indicate when an Alarm occurs. Active low.
11	Alarm Select 1	Used by FACP for automatic alarm control of zone outputs. Active low.
12	Alarm Select 2	
13	Alarm Select 3	
14	Alarm Select 4	
15	GND	Ground
16	Trouble Out	Trouble output, active low.

5.1.3 Terminal Strip 3

This section describes what the terminal connections of terminal strip 3 are used for.

Terminal Number	Name	Description
17	GND	Ground
18		Not Used.
19		Not Used.
20		
21		
22		
23	GND	Ground
24	Select All	Not Used.

5.1.4 Terminal Strip 4

This section describes what the terminal connections of terminal strip 4 are used for.

Terminal Name	Description
SP1 +	Speaker output 1 positive connection.
SP1 –	Speaker output 1 negative connection.
SPR1 +	Speaker 1 return positive connection, used for Class A (Style Z) configuration.
SPR1 –	Speaker 1 return negative connection, used for Class A (Style Z) configuration.
SP2 +	Speaker output 2 positive connection.
SP2 –	Speaker output 2 negative connection.
SPR2 +	Speaker 2 return positive connection, used for Class A (Style Z) configuration.
SPR2 –	Speaker 2 return negative connection, used for Class A (Style Z) configuration.

5.1.5 Terminal Strip 5

This section describes what the terminal connections of terminal strip 5 are used for.

Terminal Name	Description
SP +	Raw speaker signal from DMR (un-split), used for End of Line supervision.
SP –	
SP4 +	Speaker output 4 positive connection.
SP4 –	Speaker output 4 negative connection.
SPR4 +	Speaker 4 return positive connection, used for Class A (Style Z) configuration.
SPR4 –	Speaker 4 return negative connection, used for Class A (Style Z) configuration.
SP3 +	Speaker output 3 positive connection.
SP3 –	Speaker output 3 negative connection.
SPR3 +	Speaker 3 return positive connection, used for Class A (Style Z) configuration.
SPR3 –	Speaker 3 return negative connection, used for Class A (Style Z) configuration.

5.1.6 Manual Zone Switches

Manual zone switches are used to manually override the system message by zone, using the microphone.

For example, if you wish to manually give a verbal evacuation message (using the microphone) to zone 4, you would turn on switch 4, then key the microphone and speak the desired message. Your spoken message would be output to the speakers in zone 4 only.

5.1.7 All Call Switch

The All Call Switch manually overrides the system message, using the microphone, to all zones in the system.

5.1.8 Zone Supervision Selectors

The zone supervision selector selects how the speaker circuit will be supervised. Speaker circuits can be Class B (Style Y) or Class A (Style Z) supervised depending on how they are connected to the control panel. (See Section 5.4 for wiring configurations.)

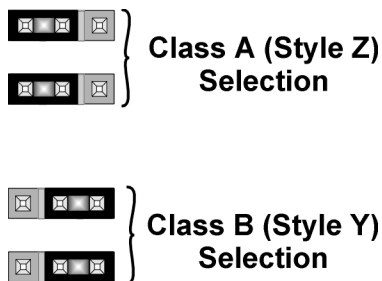

Figure 5-2 Speaker circuit Supervision Selections

5.1.9 LED Descriptions

The SKE-ZN4 has two LEDs for each zone, an Active and a Trouble LED. The Active LED (Red) indicates that the zone is activated when it is ON. The Trouble LED (Yellow), when on, indicates the 15 kΩ end of line resistor on the speaker circuit is missing.

5.2 SKE-ZN4 Specifications

Circuit	Rating	
Operating Voltage:	24 VDC	
Current Draw:	Standby:	45 mA
	Alarm:	All channels active 250 mA
Humidity	93% non-condensing max.	

5.3 Mounting the SKE-ZN4 In the SKE-450 Cabinet

This section contains instructions on how to install the SKE-ZN4 Zone Splitter into the SKE-450 Voice Evacuation cabinet.

Follow these steps to install the SKE-ZN4 into the SKE-450 cabinet:

1. Unlock and open the SKE-450 control panel cabinet door.
2. Open the control panel cover door by removing the two retaining screws and rotating the door to the left.

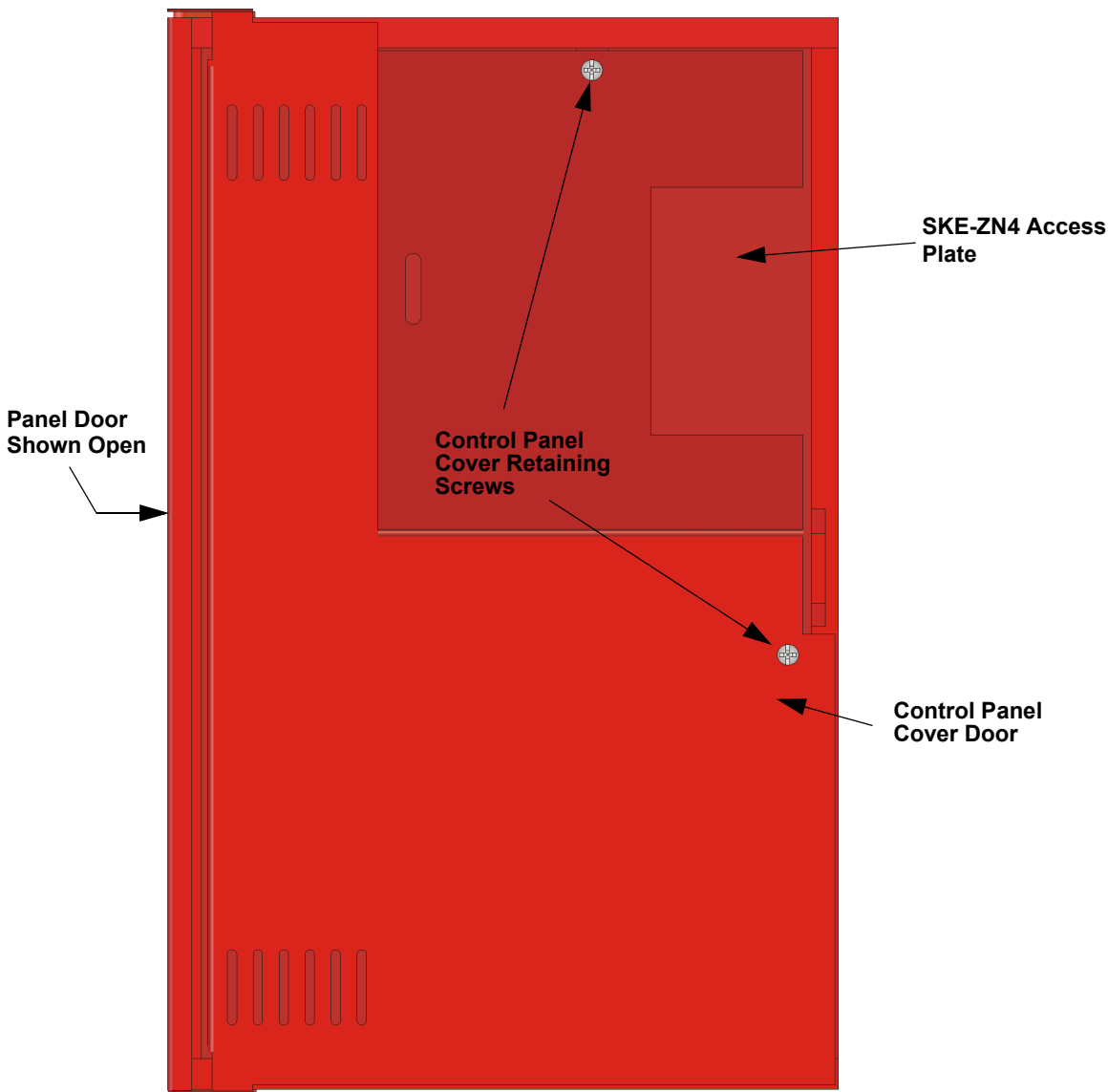

Figure 5-3 SKE-450 Cabinet With Control Panel Cover In Place

3. Remove the SKE-ZN4 access plate.

4. Mount the SKE-ZN4 to the SKE-450 cabinet mounting standoffs with the 7/10” screw-in standoffs provided.

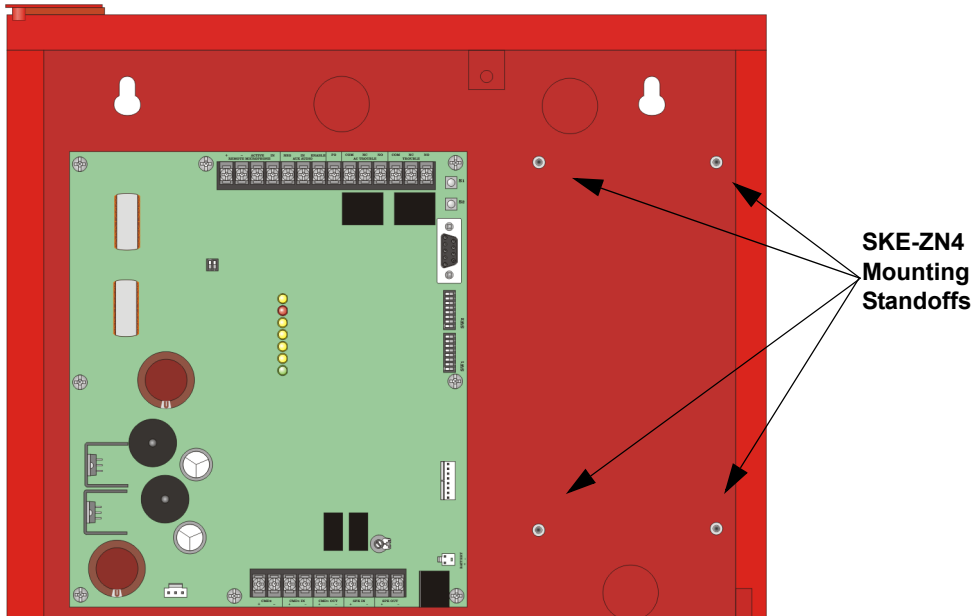

Figure 5-4 SKE-ZN4 Mounting Standoff Locations

5. Connect wiring harness to the expansion connector on the SKE-450 and to the direct connect pins on the SKE-ZN4. See Figure 5-5.

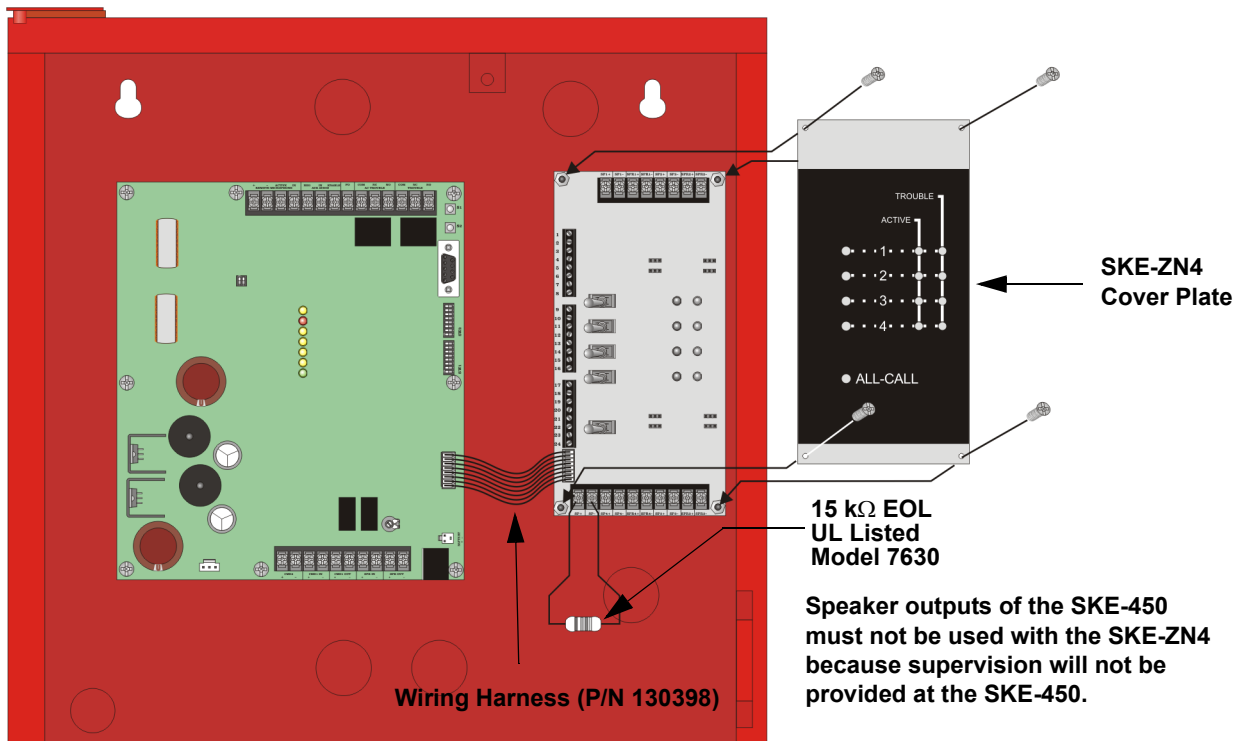

Figure 5-5 View With SKE-ZN4 Installed

6. Wire speaker to zone outputs as required by installation specifications. See Section 5.4.
7. Attach the SKE-ZN4 cover plate to the SKE-ZN4. See Figure 5-5.

5.4 Speaker Wiring

Each SKE-ZN4 supplies four Notification Appliance Circuits for speaker connection. The circuits can be supervised and wired Class B (Style Y) or Class A (Style Z). Each circuit is capable of 50 watts of power. **Note:** The system can support a maximum of 50 watts of power.

Note: This configuration illustrates a 25V installation if using an SKE-V70. For 70.7V installations, see Section 8.

5.4.1 Wiring Procedure

In order to gain access to the terminals on the SKE-ZN4, the cover plate must be removed. See Figure 5-5.

5.4.2 Class B (Style Y)

Figure 5-6 illustrates how to wire speakers to the control panel using Class B (Style Y) supervision. Make sure that the Speaker Circuit Supervision Selector is in the Class B (Style Y) position. See Figure 5-2 for Speaker Circuit Supervision Selections.

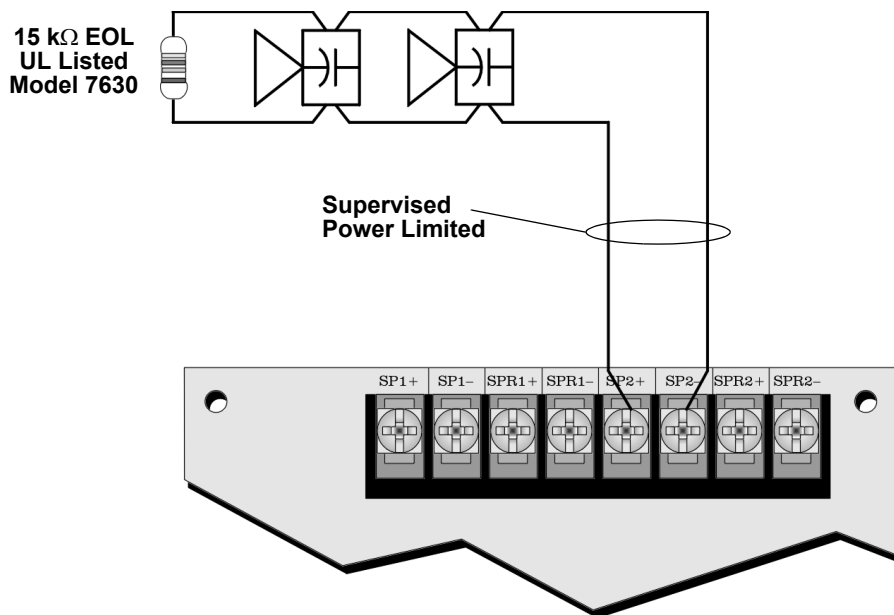

Figure 5-6 Class B (Style Y) Speaker Configuration

Note: Figure 5-6 uses Speaker Circuit 1 as an example of the wiring. All other speaker circuits are configured to their respective terminals in the same manner.

5.4.3 Class A (Style Z)

Figure 5-7 illustrates how to wire speaker circuits to the control panel in a Class A (Style Z) configuration. Make sure that the Speaker Circuit Supervision Selector is in the Class A (Style Z) position. See Figure 5-2 for Speaker Circuit Supervision Selections.

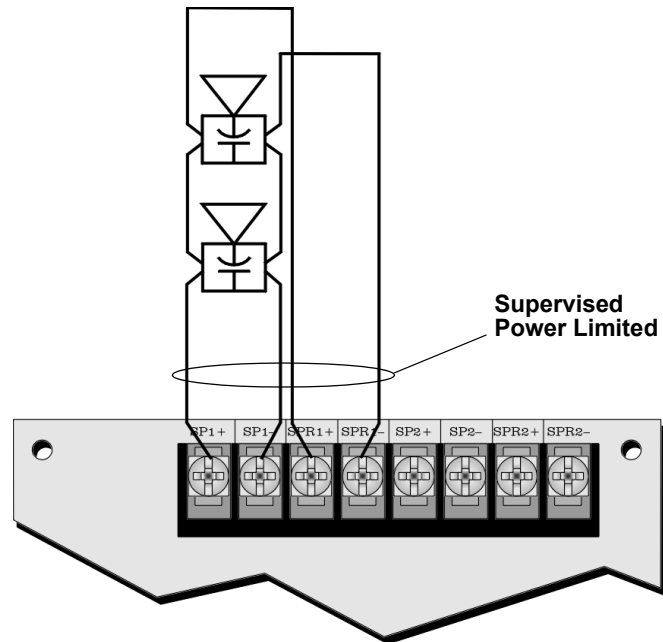

Figure 5-7 Class A (Style Z) Speaker Configuration

Note: Figure 5-7 uses Speaker Circuit 1 as an example of the wiring. All other speaker circuits are configured in to their respective terminals the same manner.

5.4.4 FACP Alarm Zone Control Wiring

This section describes how to connect relay outputs from a FACP to control the four separate zones on the SKE-ZN4 four zone splitter.

Connect an active low relay or contact from the FACP to the Alarm Selects on the SKE-ZN4 (see Figure 5-8).

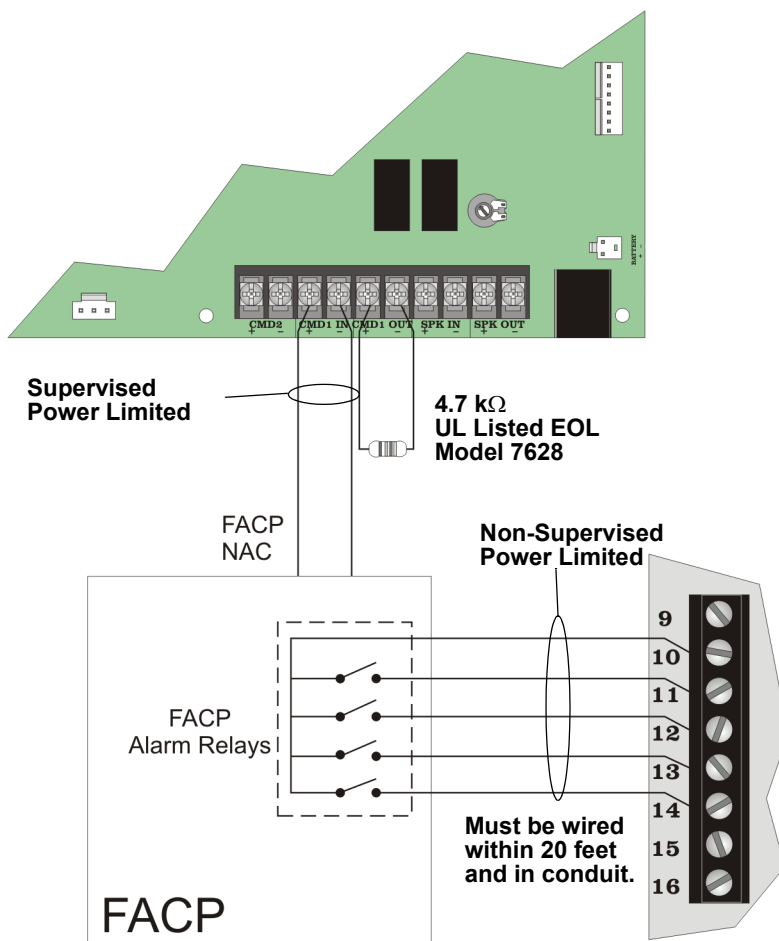

Figure 5-8 FACP Alarm Zone Control Outputs

5.4.5 General Alarm Control Wiring

This section describes general alarm control wiring as shown in Figure 5-9.

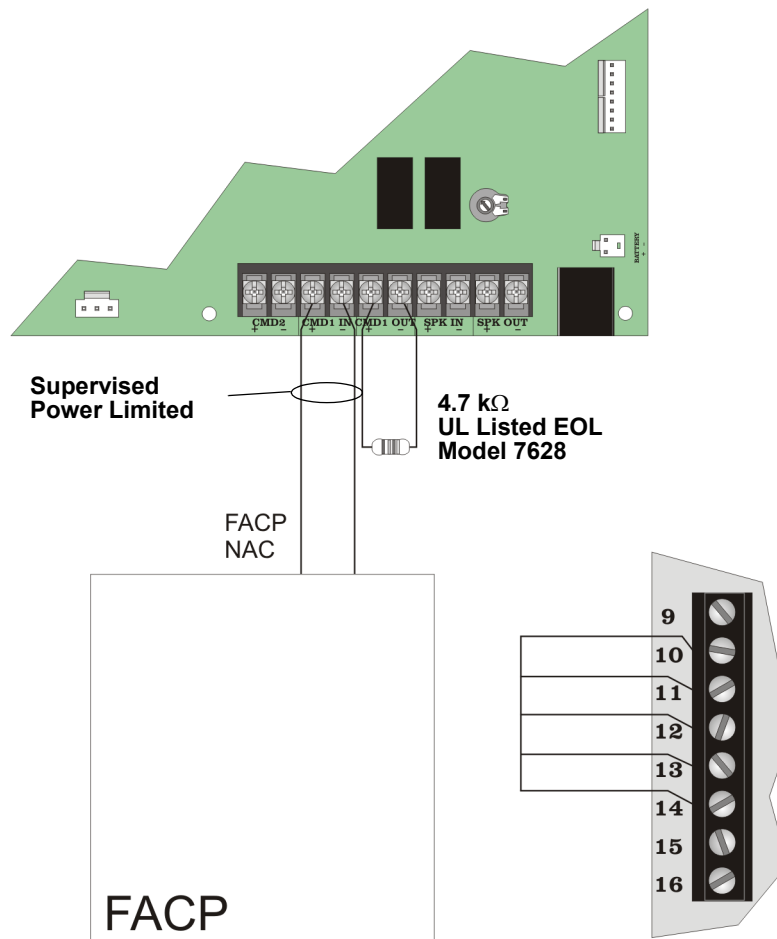

Figure 5-9 General Alarm Control Wiring

Section 6

SKE-ZN6 Six Zone Splitter Installation

This section contains information on how to install the SKE-ZN6 Zone Splitter into the SKE-450 cabinet, and how to connect input and output devices to the zone splitter.

A zone splitter is a device that can split the audio output from the main amp into separate audio output channels. The SKE-ZN6 is capable of splitting the audio to six separate zones.

The SKE-ZN6 can be used in installations where the audio needs to be split to different floors or zones to accommodate a safe and efficient evacuation process.

Important: See Section 6.4.4 and 6.4.5 for output control of speaker circuits by zone or general alarm.

Note: Each speaker circuit is capable of 20 watts maximum power not to exceed 50 watts for the system.

6.1 SKE-ZN6 Board and Components

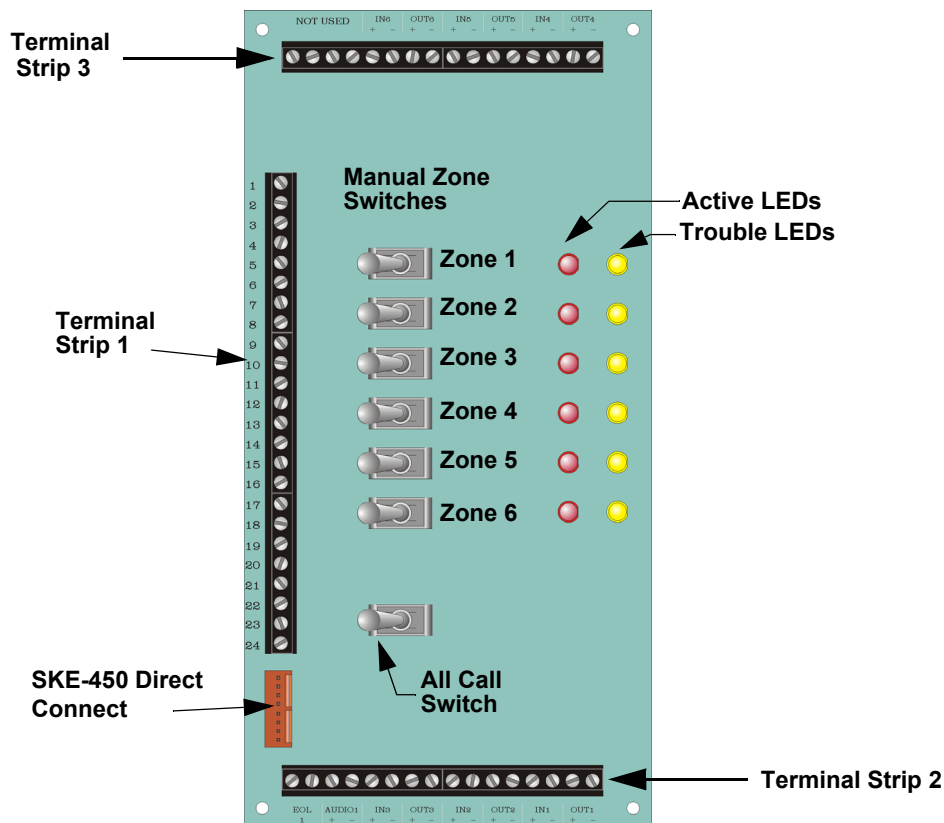

Figure 6-1 SKE-ZN6 Board Components

6.1.1 Terminal Strip 1

This sections describes what the terminal connections of terminal strip 1 are used for.

Terminal Number	Name	Description
1	+24 VDC	Positive 24 VDC in or out.
2	GND	Ground
3	Trouble Out	Trouble output, active low.
4	GND	Ground
5	Select All	Not Used
6		Not Used
7		
8	GND	Ground
9	GND	Ground
10	Alarm Active	Signal input from main DMR to indicate when an Alarm occurs. Active low.
11	Alarm Select 1	Used by FACP for automatic alarm control of zone outputs. Active low.
12	Alarm Select 2	
13	Alarm Select 3	
14	Alarm Select 4	
15	Alarm Select 5	
16	Alarm Select 6	
17	GND	Ground
18	MIC Active	Signal input from main DMR to indicate when the microphone has been activated. Active low.
19	Not Used	Not Used
20	Not Used	
21	Not Used	
22	Not Used	
23	Not Used	
24	Not Used	

6.1.2 Terminal Strip 2

This sections describes what the terminal connections of terminal strip 5 are used for.

Terminal Name		Description
EOL 1		Raw speaker signal from DMR (un-split), used for End of Line supervision.
AUDIO1	+	Not Used.
	-	
IN6	+	Speaker 6 return positive connection, used for Class A (Style Z) configuration.
	-	Speaker 6 return negative connection, used for Class A (Style Z) configuration.
OUT6	+	Speaker output 6 positive connection, used for Class B (Style Y) configuration.
	-	Speaker output 6 negative connection, used for Class B (Style Y) configuration.
IN5	+	Speaker 5 return positive connection, used for Class A (Style Z) configuration.
	-	Speaker 5 return negative connection, used for Class A (Style Z) configuration.
OUT5	+	Speaker output 5 positive connection, used for Class B (Style Y) configuration.
	-	Speaker output 5 negative connection, used for Class B (Style Y) configuration.
IN4	+	Speaker 4 return positive connection, used for Class A (Style Z) configuration.
	-	Speaker 4 return negative connection, used for Class A (Style Z) configuration.
OUT4	+	Speaker output 4 positive connection, used for Class B (Style Y) configuration.
	-	Speaker output 4 negative connection, used for Class B (Style Y) configuration.

6.1.3 Terminal Strip 3

This sections describes what the terminal connections of terminal strip 4 are used for.

Terminal Name	Description	
Not Used		
IN3	+	Speaker 3 return positive connection, used for Class A (Style Z) configuration.
	-	Speaker 3 return negative connection, used for Class A (Style Z) configuration.
OUT3	+	Speaker output 3 positive connection, used for Class B (Style Y) configuration.
	-	Speaker output 3 negative connection, used for Class B (Style Y) configuration.
IN2	+	Speaker 2 return positive connection, used for Class A (Style Z) configuration.
	-	Speaker 2 return negative connection, used for Class A (Style Z) configuration.
OUT2	+	Speaker output 2 positive connection, used for Class B (Style Y) configuration.
	-	Speaker output 2 negative connection, used for Class B (Style Y) configuration.
IN1	+	Speaker 1 return positive connection, used for Class A (Style Z) configuration.
	-	Speaker 1 return negative connection, used for Class A (Style Z) configuration.
OUT1	+	Speaker output 1 positive connection, used for Class B (Style Y) configuration.
	-	Speaker output 1 negative connection, used for Class B (Style Y) configuration.

6.1.4 Manual Zone Switches

Manual zone switches are used to manually override the system message, using the microphone, by zone.

For example, if you wish to manually give an evacuation message (using the microphone) to zone 4, you would turn on switch 4, then key the microphone and speak the desired message. Your manually-spoken message would be output to the speakers in zone 4 only.

6.1.5 All Call Switch

The All Call Switch manually overrides the system message, using the microphone, to all zones in the system.

6.1.6 LED Descriptions

The SKE-ZN6 has two LEDs for each zone, an Active and a Trouble LED. The Active LED (Red) indicates that the zone is activated when it is ON. The Trouble LED (Yellow), when on, indicates that it does not detect the 15 kΩ end of line resistor on the speaker loop.

6.2 SKE-ZN6 Specifications

Circuit	Rating	
Operating Voltage:	24 VDC	
Current Draw:	Standby:	30 mA
	Alarm:	All channels active 120 mA
Humidity	93% non-condensing max.	

6.3 Mounting the SKE-ZN6 In the SKE-450 Cabinet

This section contains instructions on how to install the SKE-ZN6 Zone Splitter into the SKE450 Voice Evacuation cabinet.

Follow these steps to install the SKE-ZN6 into the SKE450 cabinet:

1. Unlock and open the SKE450 control panel cabinet door.
2. Remove the control panel cover door retaining screws.

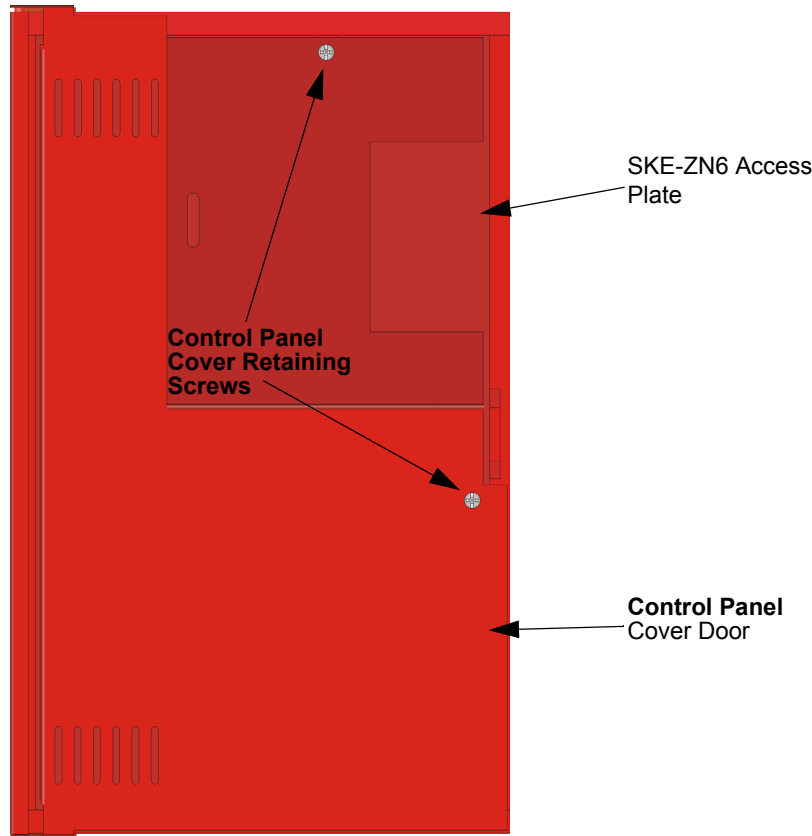

Figure 6-2 SKE450 Cabinet With Control Panel Cover In Place

3. Swing the control panel cover door open.

4. Remove the SKE-ZN6 access plate.
5. Mount the SKE-ZN6 to the SKE450 cabinet mounting standoffs with the 7/10" screw-in standoffs provided.

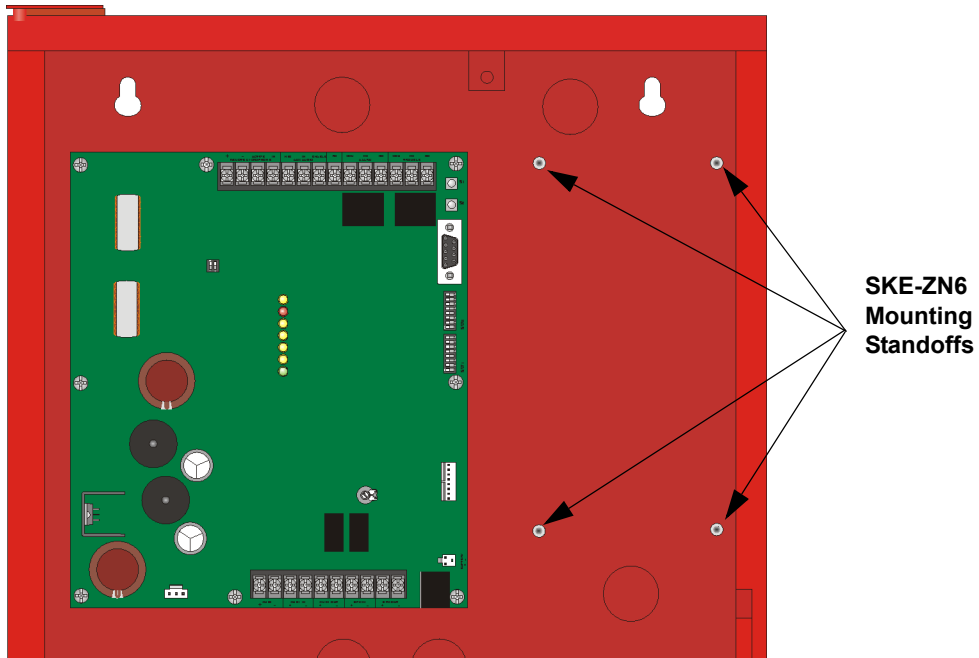

Figure 6-3 SKE-ZN6 Mounting Standoff Locations

- Connect wiring harness to the expansion connector on the SKE450 and to the direct connect pins on the SKE-ZN6. See Figure 6-4.

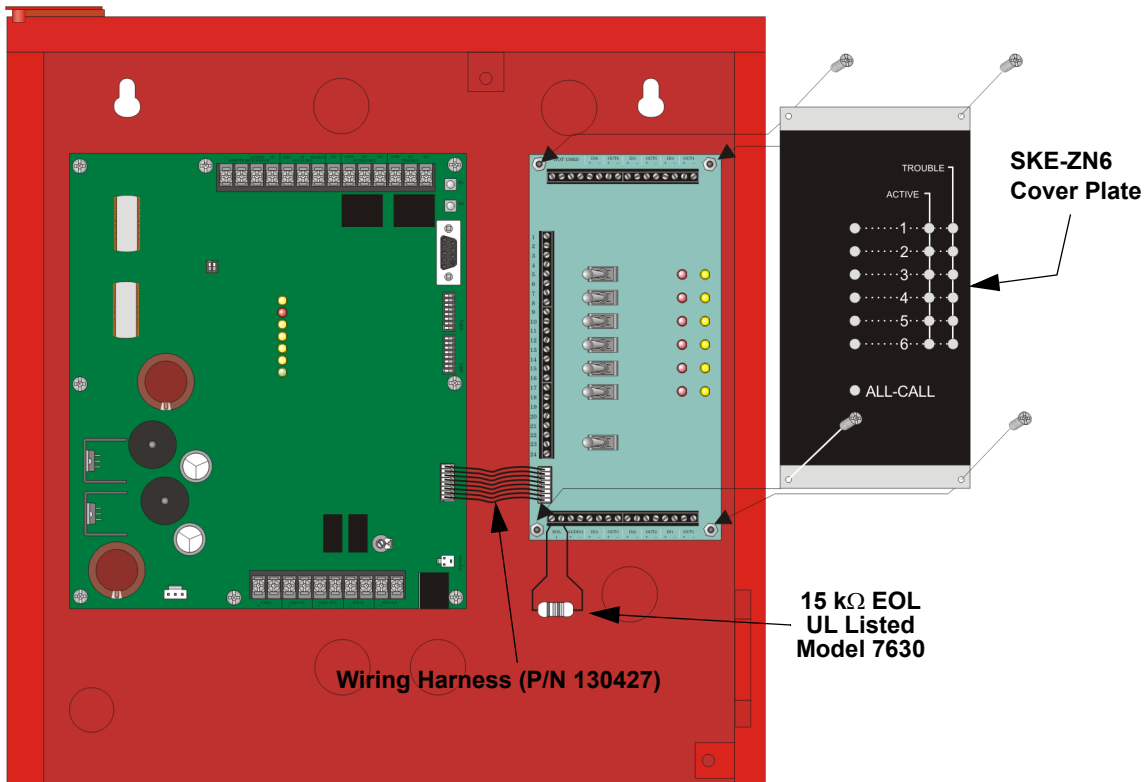

Figure 6-4 View With SKE-ZN6 Installed

- Wire speaker to zone outputs as required by the installation specifications. Refer to Section 6.4.
- Attach the SKE-ZN6 cover plate to the SKE-ZN6. See Figure 6-4.

Note: Speaker outputs of the SKE-450 must not be used when using the SKE-ZN6 because supervision will not be provided at the SKE-450.

6.4 Speaker Wiring

Each SKE-ZN6 supplies six NACs (Notification Appliance Circuits) for speaker connection. The speaker circuits can be supervised and wired Class B (Style Y) or Class A (Style Z). Each speaker circuit is capable of 20 watts of power.

Note: This configuration illustrates a 25V installation if using an SKE-V70. For 70.7V installations, see Section 8.

6.4.1 Wiring Procedure

In order to gain access to the terminals on the SKE-ZN6, the cover plate must be removed. See Figure 6-4.

6.4.2 Class B (Style Y)

Figure 6-5 illustrates how to wire speakers to the control panel using Class B (Style Y) supervision.

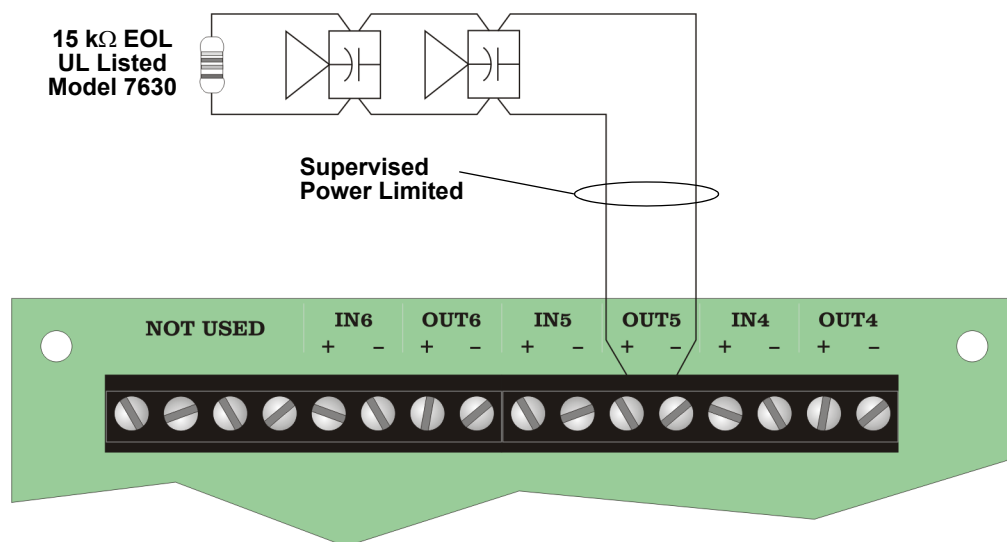

Figure 6-5 Class B (Style Y) Speaker Configuration

Note: Figure 6-5 uses Speaker Loop 5 as an example of the wiring. All other speaker loops are configured in the same manner to their respective OUT terminals.

6.4.3 Class A (Style Z)

Figure 6-6 illustrates how to wire speakers to the control panel using Class A (Style Z) supervision.

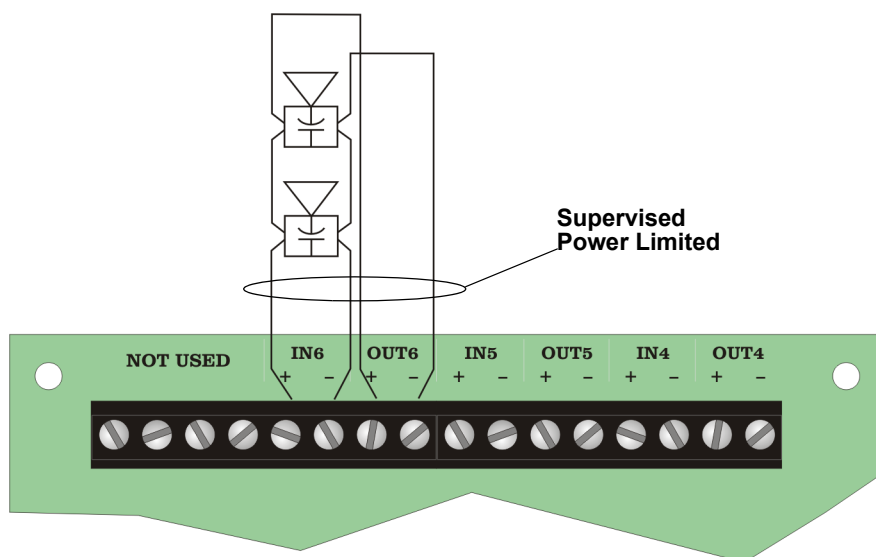

Figure 6-6 Class A (Style Z) Speaker Configuration

Note: Figure 6-6 uses Speaker Loop 1 as an example of the wiring. All other speaker loops are configured in the same manner to their respective terminals.

6.4.4 FACP Alarm Zone Control Wiring

This section describes how to connect relay outputs from a FACP to control the six separate zones on the SKE-ZN6 six zone splitter.

Connect an active low relay or contact from the FACP to the Alarm Selects on the SKE-ZN6 (see Figure 6-7).

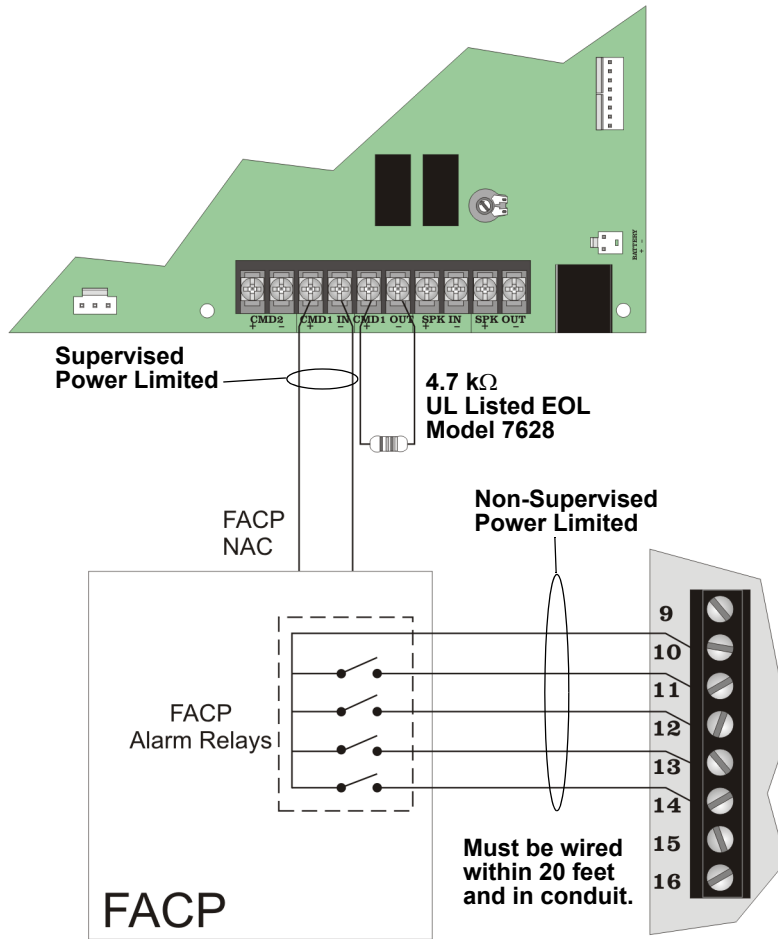

Figure 6-7 FACP Alarm Control Outputs

6.4.5 General Alarm Control Wiring

This section describes general alarm control wiring as shown in Figure 6-8.

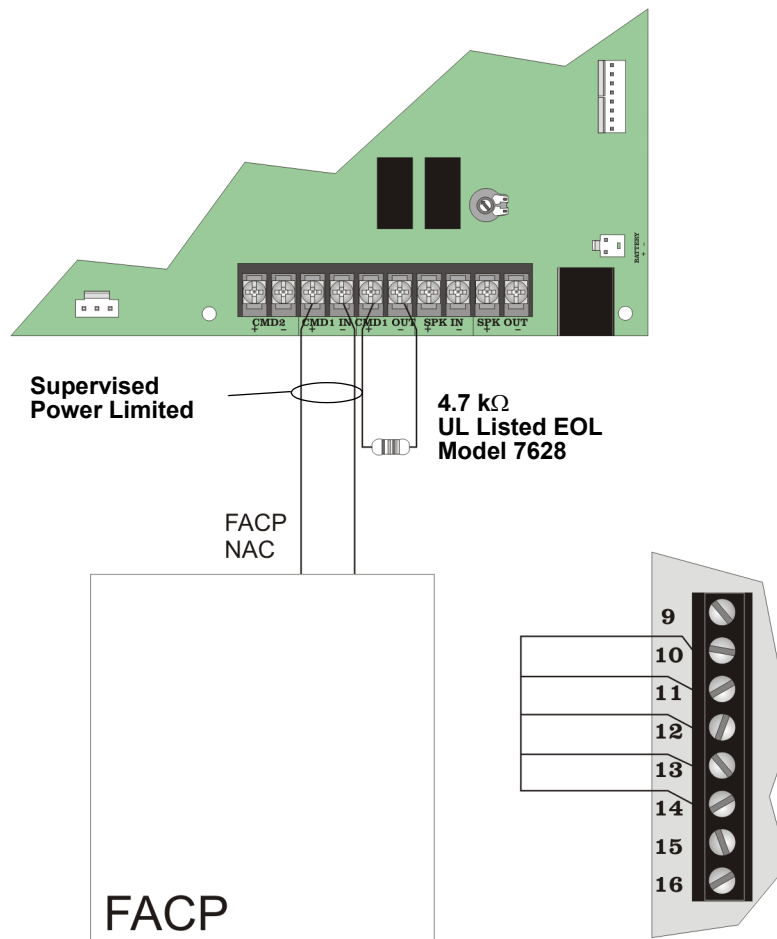

Figure 6-8 General Alarm Control Wiring

Section 7

SKE-SRM

The SKE-SRM is a supervised remote microphone assembly that can be added to the SKE-Series voice evacuation system.

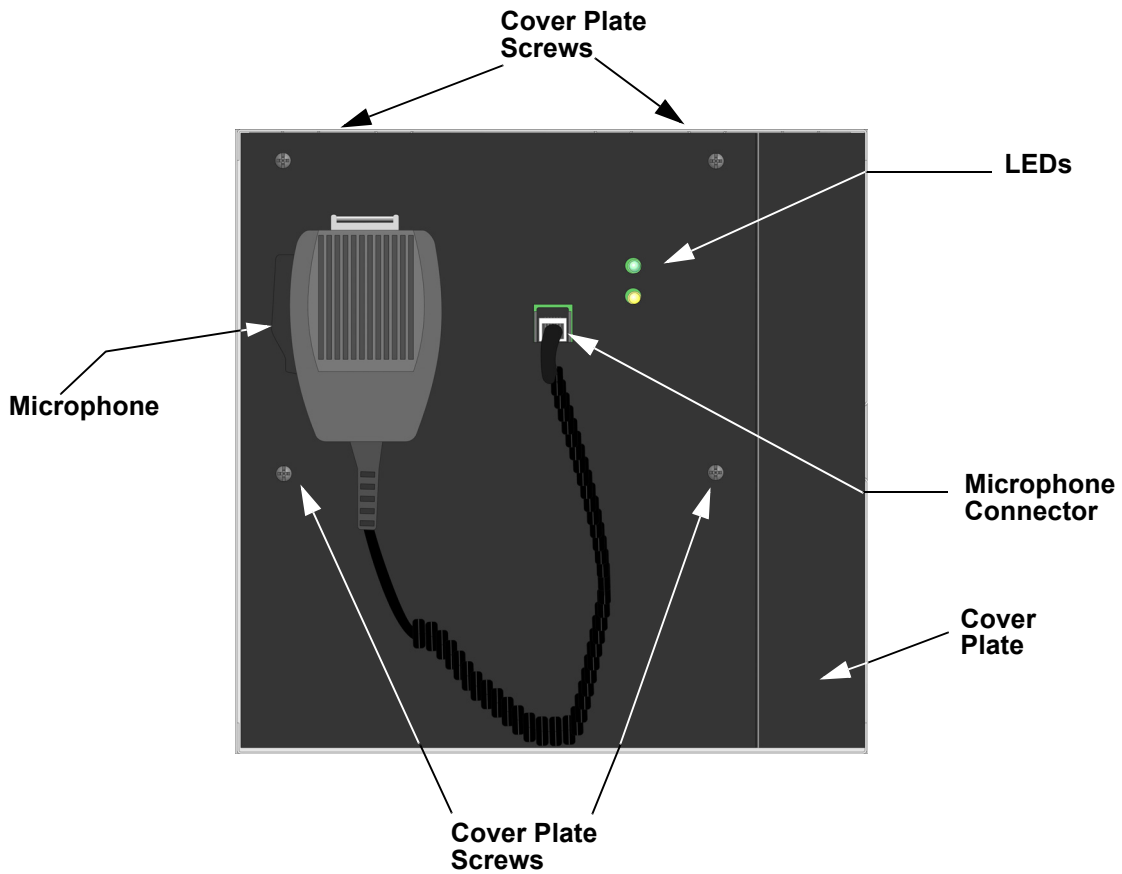

Figure 7-1 The SKE-SRM

7.1 Specifications

Parameter		Rating
Operating Voltage:		24 VDC
Current Draw:	Standby:	30 mA
Dimensions:	Height:	10-1/4" (26.04 cm)
	Width:	10-3/8" (26.35 cm)
	Depth:	3-1/8" (7.94 cm)
Operating Temperature:		0°C-49°C (32°F-120°F)
Humidity		93% non-condensing max.

7.2 LED Description

LED	State	Meaning
Green	On	Remote microphone has DC power.
	Off	Remote microphone has no power or has a major malfunction.
Yellow	On	No microphone attached to the unit.
	Off	Microphone is connected.

7.3 Installation Instructions

This section contains the information needed to properly install the SKE-SRM.

7.3.1 Mounting the SKE-SRM Cabinet.

It is important to protect the SKE-SRM control panel from water. To prevent water damage, the following conditions should be avoided when installing the units:

- Do not mount directly on exterior walls, especially masonry walls (condensation)
- Do not mount directly on exterior walls below grade (condensation)
- Protect from plumbing leaks
- Protect from splash caused by sprinkler inspection ports
- Do not mount in areas with humidity-generating equipment (such as dryers, production machinery)

When selecting a location to mount the SKE-SRM cabinet, the unit should be mounted where it will NOT be exposed to temperatures outside the range of 0°C-49°C (32°F-120°F) or humidity outside the range of 10%-85% at 30°C (86°F) noncondensing.

Follow these steps to mount the remote microphone cabinet:

1. Remove the SKE-SRM from it's packing container.
2. Unlock the cabinet and remove the cabinet door.
3. Unplug microphone from microphone connector. See Figure 7-1.

Place microphone in a safe location while completing cabinet installation.

4. Remove the cover plate by un-screwing the four cover plate screws (see Figure 7-1). Set the screws aside for later use.
5. Remove the remote microphone chassis assembly by un-screwing the two chassis assembly screws. See Figure 7-2.

Important! The electronic components on the control panel are sensitive to electrostatic discharge (static electricity). Wear a grounding strap when handling the control board.

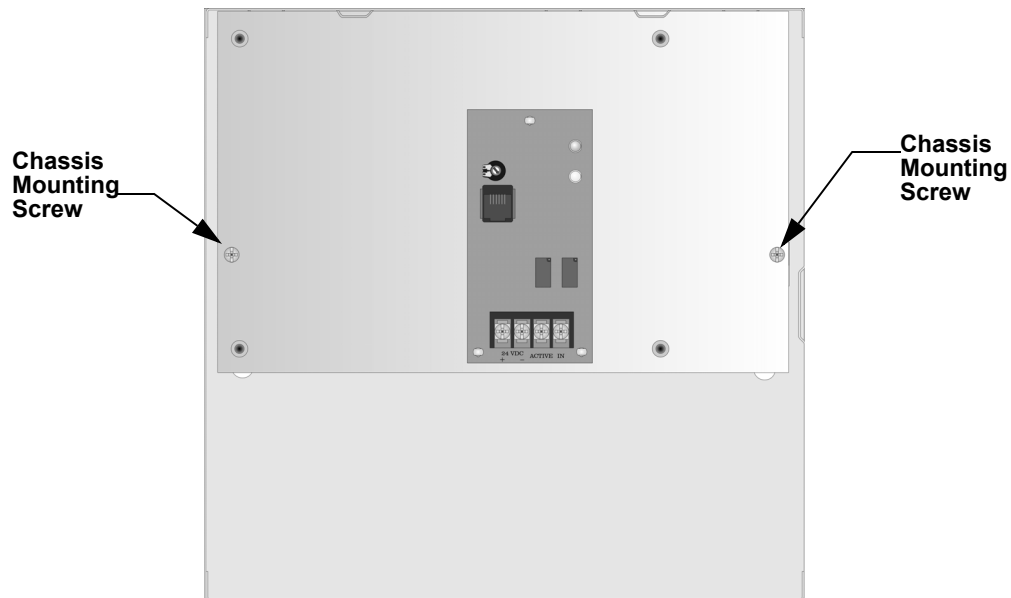

Figure 7-2 Remote Microphone Chassis Assembly

6. Mount the cabinet using the appropriate screws and anchors, through the cabinet mounting holes. See Figure 7-3.

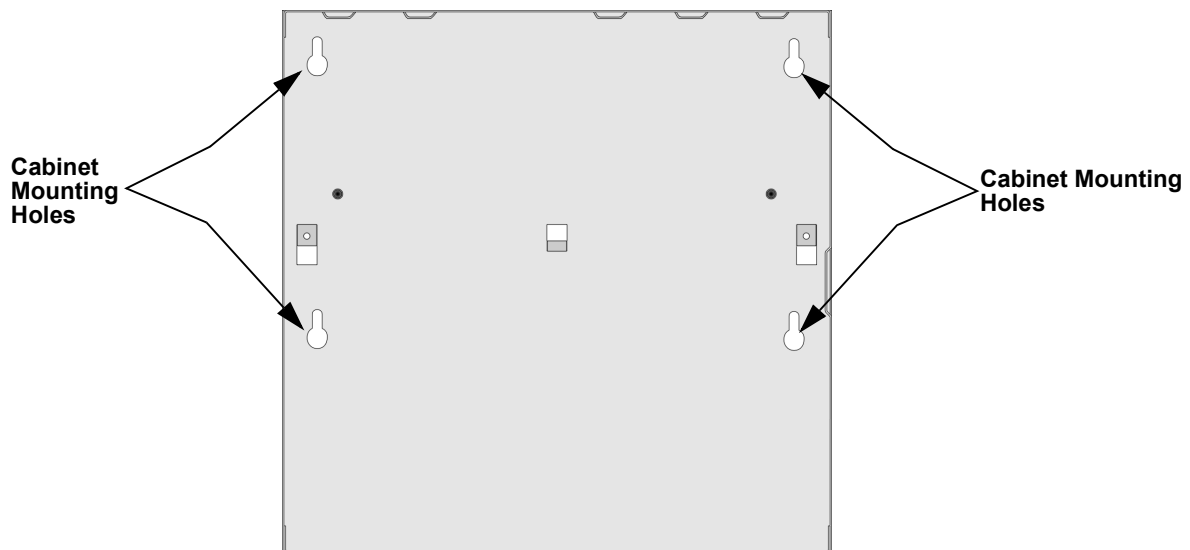

Figure 7-3 Cabinet Mounting Hole Locations

7. Run any wires needed for the installation. See Section 7.3.2 for more information about wire requirements.

7.3.2 Wiring Instructions

The wiring for the remote microphone should use shielded 4 conductor 22AWG (up to 5000 feet) wiring. The wiring is supervised by the main panel if switch 4 on SW2 is set to ON (see Table 4-1).

Figure 7-4 illustrates how to wire the SKE-SRM to the main control panel. See also Table 7-1.

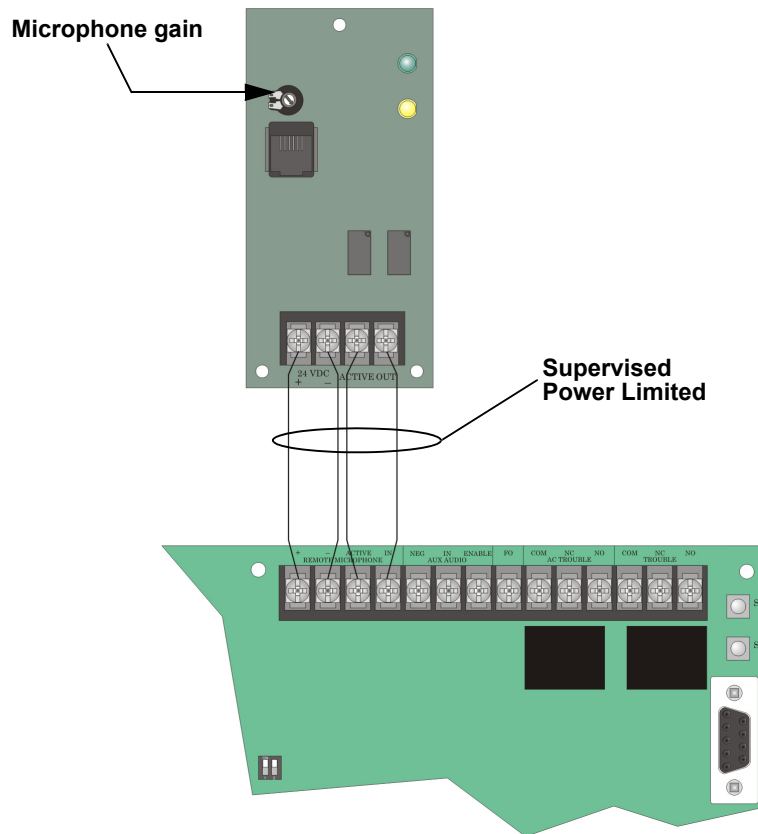

Figure 7-4 The SKE-SRM Wiring Connections to the SKE-450

Table 7-1: Wire Terminations

Remote Mic Terminals	Main Control Terminals			
	Remote Microphone			
	+	-	Active	In
+	Connect to			
-		Connect to		
Active			Connect to	
Out				Connect to

7.3.3 Remote Microphone Operation

Use the mic gain on the board to adjust audio to desired level. See Figure 7-4 for mic gain location. The system can support a maximum of one remote microphone.

Table 7-2 describes the remote microphones LEDs.

Table 7-2: LED Descriptions

LED Color	State	Meaning
Green	On	The remote microphone has DC power.
	Off	No DC power.
Yellow	On	Local trouble, indicating that the microphone is not plug into the remote microphone jack.
	Off	Microphone is connected properly.

Main mic on the SKE-450 overrides the remote mic.

In normal mode, remote microphone can be used for emergency use only. Voice will be broadcasted via the main panel.

In alarm mode, the remote microphone can be used to interrupt any prerecorded messages to allow manual evacuation. The remote microphone will operate in an "ALL-CALL" mode.

This page left blank intentionally.

Section 8

SKE-V70 Module Installation

The SKE-V70 converts the speaker circuit voltage from 25 Vrms to 70.7 Vrms. The following sections describe how to install and wire the SKE-V70.

8.1 Mounting

Follow these steps to install the SKE-V70 module into the main control panel cabinet:

1. Unlock and open the cabinet door.
2. Remove the two cover plate retaining screws, then open the control panel cover plate. See Figure 8-1.

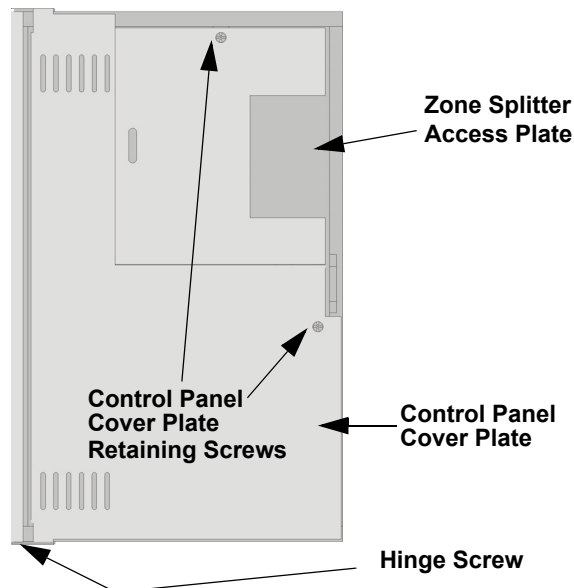

Figure 8-1 View of Cabinet With Cover Plate in Place

Note: The control panel cover plate can be remove by removing the Hinge screw.

3. Run all wire needed to install the system at this time. See Section 8.2.

4. Mount the module into the cabinet as shown in Figure 8-2.

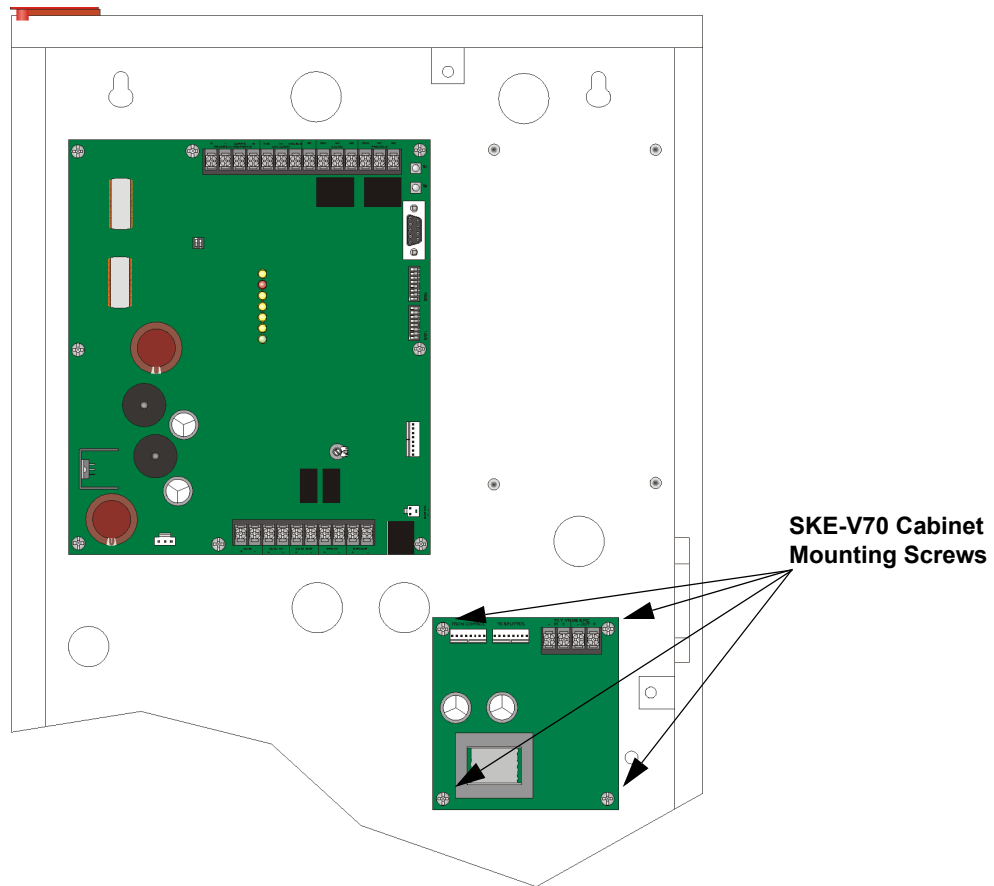

Figure 8-2 Main Control Board Mounting Location

5. Connect wiring as described in Section 8.2.

8.2 Speaker Wiring

Each SKE-V70 supplies one NAC (Notification Appliance Circuit) for speaker connection. The speaker circuit can be supervised and wired Class B (Style Y) or Class A (Style Z). The speaker circuit is capable of 50 watts of power 70.7 Vrms (using the SKE-V70 Module). Refer to Table 3-7 for wire lengths.

Note: When the SKE-V70 Module is installed, all speaker wiring must be separated by a minimum of 1/4" from the low voltage wiring, and must exit the cabinet through its own opening.

8.2.1 Connecting the SKE-V70 to the Main Control Panel

Connect the SKE-V70 to the main control panel using the supplied wire harness. See Figure 8-3.

Note: Speaker outputs of the SKE-450 must not be used when using the SKE-V70 because supervision will not be provided at the SKE-450.

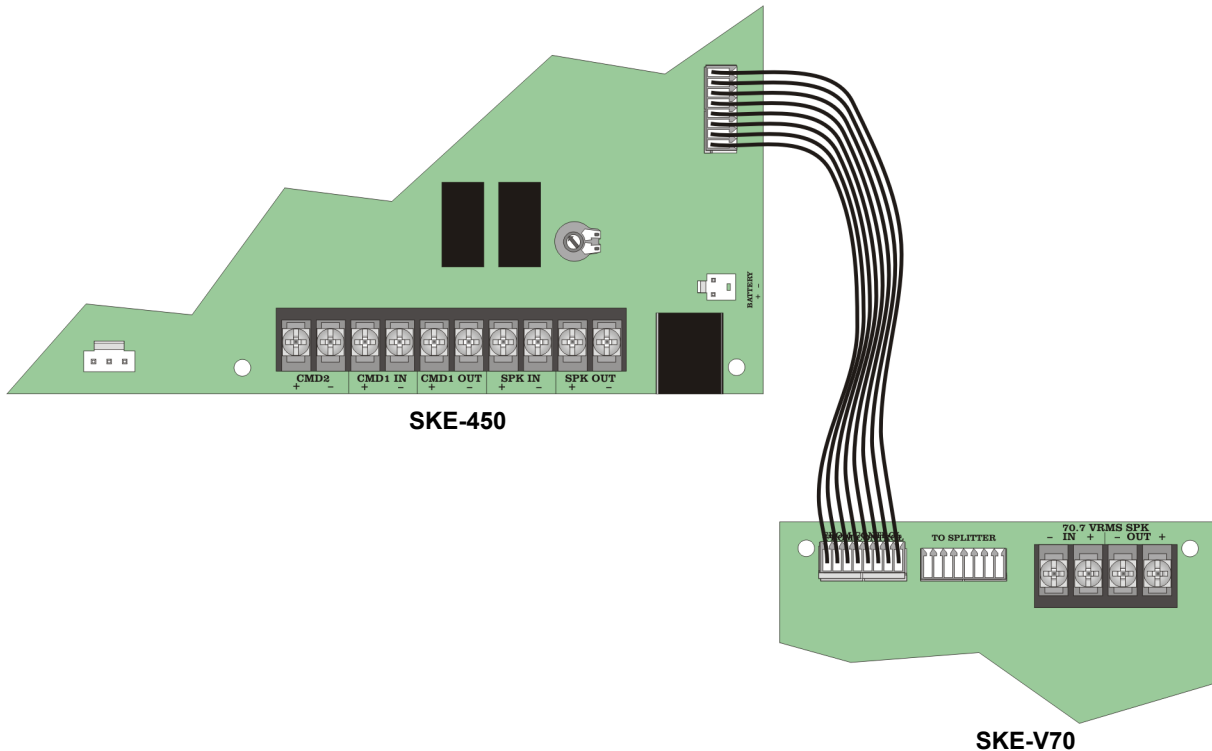

Figure 8-3 Wire Harness Connection From the Main Control to the SKE-V70

8.2.2 Class B (Style Y) Wiring to the SKE-V70

Figure 8-4 illustrates how to wire speakers to the SKE-V70 using Class B (Style Y) supervision.

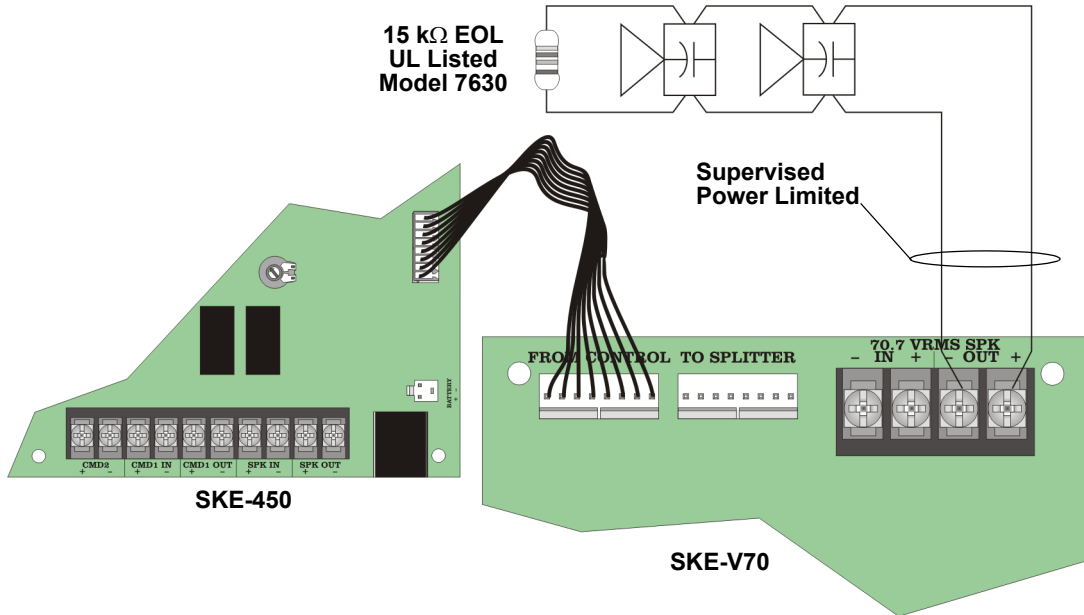

Figure 8-4 Class B (Style Y) Speaker Configuration

8.2.3 Class A (Style Z) Wiring to the SKE-V70

Figure 8-5 illustrates how to wire speakers to the SKE-V70 using Class A (Style Z) wiring.

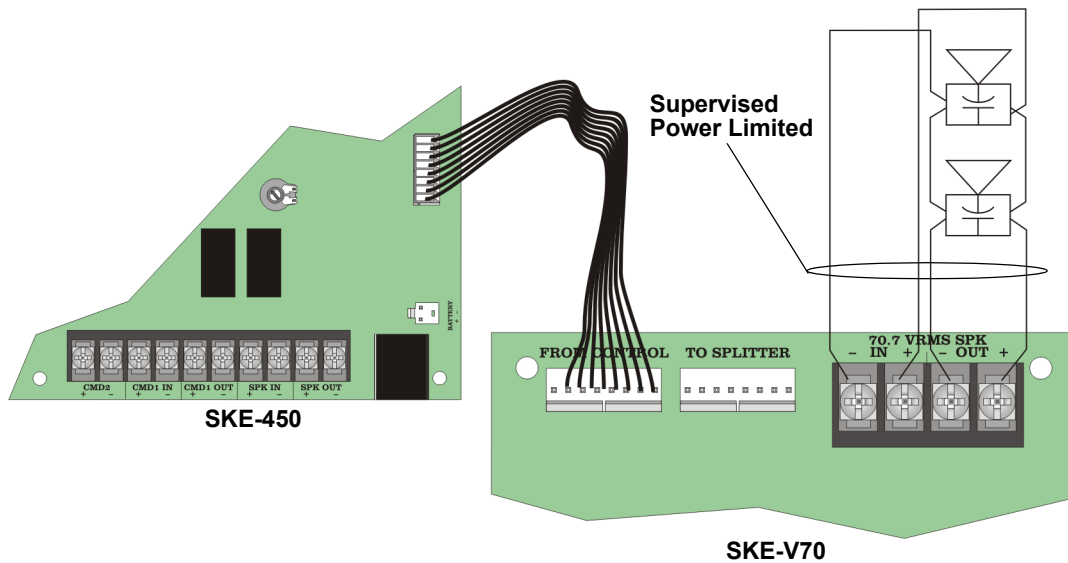

Figure 8-5 Class A (Style Z) Speaker Configuration

8.2.4 Connecting the SKE-V70 to the SKE-ZN4 or -ZN6

If the optional 4 or 6 zone splitter is used in the system connect the wire harnesses as follows:

1. Connect one harness from the main control to the SKE-V70 connector marked “FROM CONTROL”. See Figure 8-6.
2. Connect the other harness from the SKE-V70 connector marked “TO SPLITTER” to the connector on the 4 or 6 zone splitter as shown in Figure 8-6.

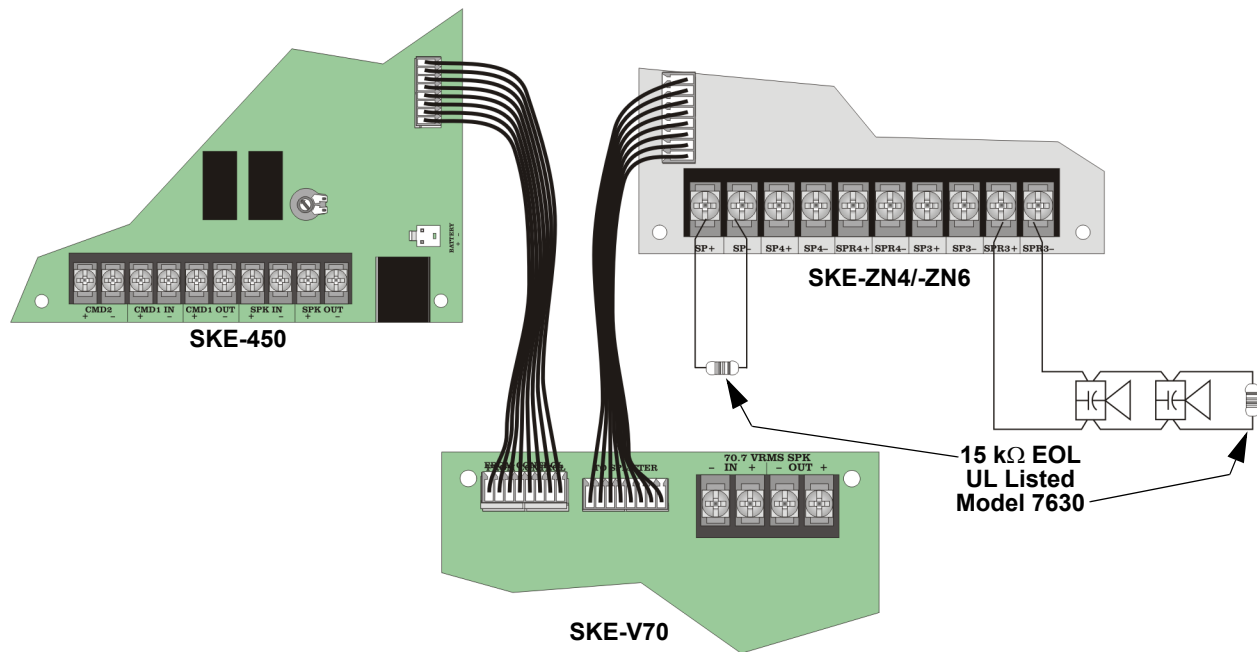

Figure 8-6 Wire Harness Connections for Splitter and Main Control

Notes: Refer to Section 5 for SKE-ZN4 installation and wiring instructions. Refer to Section 6 for SKE-ZN6 installation and wiring instructions.

Speaker outputs of SKE-450 and the SKE-V70 must not be used when using either SKE-ZN4/-ZN6 in combination with SKE-V70 because supervision will not be provided at the SKE-450 and the SKE-V70.

This page left blank intentionally.

Section 9

Battery Calculation

9.1 Calculating Current Draw and Standby Battery

This section enables you to determine the current draw and standby battery needs for your installation (18 Ampere Hours maximum).

Batteries larger than 18 AH will not fit into the main control cabinet, and must be housed in the RBB Accessory Battery Cabinet. See Section 3.8.2 for battery installation.

Lines A through D have been completed for you. Complete the remaining instructions in Table 9-1 to determine battery size requirements.

Table 9-1: Current Draw Calculations

Device	Number of Devices	Current per Device	Standby Current	Alarm Current
Main Control Panel	1	Standby: 140 mA	140 mA	
		Alarm: 590 mA		590 mA
SKE-ZN4	1	Standby: 45 mA	mA	
		Alarm: All Channels 250 mA		mA
SKE-ZN6	1	Standby: 35 mA	mA	
		Alarm: All Channels 120 mA		mA
SKE-SRM	1	Standby: 30 mA	mA	
		Alarm: 30 mA		mA
SKE-V70	1	Standby: 10 mA	mA	
		Alarm: 70 mA		mA
A	Current Subtotals:		mA	mA
	Notification Devices	Refer to device manual for number of devices and current ratings.		
	Full Load (50 watts)*	Alarm: 2250 mA		mA
B	Current Subtotals:		mA	mA
C	Total current rating of all devices in system (add TOTALS OF A-C) X .001:		A	A
D	Number of standby hours. (24 or 60 for NFPA 72, chapter 1, 1-5.2.5):		H	
E	Multiply lines C (standby current) and D: Total standby AH		AH	
F	Alarm sounding period in hours. (For example, 5 minutes = .0833 hours)			H
G	Multiply lines C (alarm current) and F: Total alarm AH			AH
H	Add lines E and G. (AH = Ampere Hours) Total AH required		AH	

* If less than 50 watts are used, calculate 45 mA per watt.

This page left blank intentionally.

Silent Knight Fire Product Warranty and Return Policy

General Terms and Conditions

- All new fire products manufactured by Silent Knight have a limited warranty period of 36 months from the date of manufacture against defects in materials and workmanship. See limited warranty statement for details.
- This limited warranty does not apply to those products that are damaged due to misuse, abuse, negligence, exposure to adverse environmental conditions, or have been modified in any manner whatsoever.

Repair and RA Procedure

- All products that are returned to Silent Knight for credit or repair require a RMA (Return Authorization) number. Call Silent Knight Customer Service at 800-328-0103 or 203-484-7161 between 8:00 A.M. and 5:00 P.M. EST, Monday through Friday to obtain a return authorization number.
- Silent Knight Technical Support is available at 800-446-6444 between 8:00 A.M. and 5:00 P.M. CST, Monday through Friday.
- All returns for credit are subject to inspection and testing at the factory before actual determination is made to allow credit.
- RMA number must be prominently displayed on the outside of the shipping box. See return address example under Advanced Replacement Policy.
- Include a packing slip that has the RMA number, a content list, and a detailed description of the problem should be included with each return.
- All products returned to Silent Knight must be sent freight pre-paid. After product is processed, Silent Knight will pay for shipping product back to customer via UPS ground.
- Return the Silent Knight product circuit board only. Products that are returned in cabinets will be charged an additional \$50 to cover the extra shipping and handling costs over board only returns. **Do not return batteries.** Silent Knight has the authority to determine if a product is repairable. Products that are deemed un-repairable will be returned to the customer.
- Product that is returned that has a board date code more than 36 months from date of manufacture will be repaired and the customer will be assessed the standard Silent Knight repair charge for that model.

Advanced Replacement Policy

- Silent Knight offers an option of advance replacement for fire product printed circuit boards that fail during the first 6 months of the warranty period. These items must be returned with transportation charges prepaid and must be accompanied by a return authorization.
- For advance replacement of a defective board contact your local Silent Knight Distributor or call Silent Knight at 203-484-7161 to obtain a RMA (Return Authorization) number and request advanced replacement,
- A new or refurbished board will be shipped to the customer. The customer will initially be billed for the replacement board but a credit will be issued after the repairable board is received at Silent Knight. All returned products must comply with the guidelines described under “General Terms and Conditions”.
- The defective board must be returned within 30 days of shipment of replacement board for customer to receive credit. No credit will be issued if the returned board was damaged due to misuse or abuse.
- Repairs and returns should be sent to:
Silent Knight / Honeywell
Attn: Repair Department
12 Clintonville Road
Northford, CT 06472
USA

RMA Number: _____

Limited Warranty

SILENT KNIGHT warrants products manufactured by it to be free from defects in materials and workmanship for thirty-six (36) months from the date of manufacture, under normal use and service. Products are date stamped at time of manufacture. The sole and exclusive obligation of SILENT KNIGHT is to repair or replace, at its option, free of charge for parts and labor, any part that is defective in materials or workmanship under normal use and service. **All returns for credit are subject to inspection and testing at the factory before actual determination is made to allow credit.** SILENT KNIGHT does not warrant products not manufactured by it, but assigns to the purchaser any warranty extended by the manufacturer of such products. This warranty is void if the product is altered or repaired by anyone other than SILENT KNIGHT or as expressly authorized by SILENT KNIGHT in writing, or is serviced by anyone other than SILENT KNIGHT or its authorized distributors. This warranty is also void if there is a failure to maintain the products and systems in which they operate in a proper and workable manner. In case of defect, secure a Return Material Authorization form from our Return Authorization Department.

This writing constitutes the only warranty made by SILENT KNIGHT, with respect to its products. SILENT KNIGHT, does not represent that its products will prevent any loss by fire or otherwise, or that its products will in all cases provide the protection for which they are installed or intended. Buyer acknowledges that SILENT KNIGHT is not an insurer and assumes no risk for loss or damages or the cost of any inconvenience, transportation damage, misuse, abuse, accident or similar incident.

SILENT KNIGHT GIVES NO WARRANTY, EXPRESS OR IMPLIED, OF MERCHANTABILITY, FITNESS FOR ANY PARTICULAR PURPOSE, OR OTHERWISE WHICH EXTENDS BEYOND THE DESCRIPTION ON THE FACE HEREOF. UNDER NO CIRCUMSTANCES SHALL SILENT KNIGHT BE LIABLE FOR ANY LOSS OF OR DAMAGE TO PROPERTY, DIRECT, INCIDENTAL OR CONSEQUENTIAL, ARISING OUT OF THE USE OF, OR INABILITY TO USE SILENT KNIGHT ALARM'S PRODUCTS. FURTHERMORE, SILENT KNIGHT SHALL NOT BE LIABLE FOR ANY PERSONAL INJURY OR DEATH WHICH MAY ARISE IN THE COURSE OF, OR AS A RESULT OF, PERSONAL, COMMERCIAL OR INDUSTRIAL USE OF ITS PRODUCTS

This warranty replaces all previous warranties and is the only warranty made by SILENT KNIGHT. No increase or alteration, written or verbal, of the obligation of this warranty is authorized.

“SILENT KNIGHT” is a registered trademark.

SKE-450 Operating Instructions

These instructions must be framed and displayed next to the panel in accordance with NFPA 72 National Fire Alarm Code for Local Fire Alarm System.

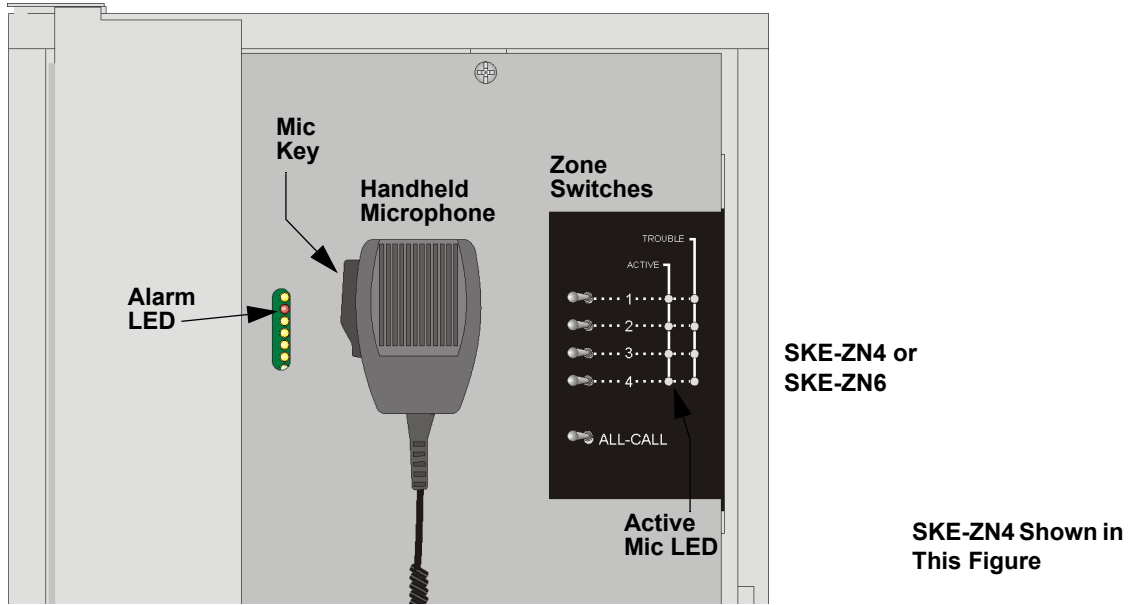

Manual Override Paging

When the system is in alarm (the red alarm LED is Lit), follow these steps to manually override the system message and notification output:

Units With SKE-ZN4 or -ZN6 Zone Splitter

1. Open the cabinet door.
2. Remove the microphone from the holder by lifting up and then out.
3. Select the zone you wish to address by turning the switch for that zone to the right.
Select ALL CALL for all zones.

Note: The LED for the zone in alarm will be lit until the microphone is keyed, then the LEDs corresponding to the zones selected will be lit.

4. While holding the microphone 1 to 2 inches from your mouth, press the mic key and deliver your message.

Units Without Zone Splitter

1. Open the cabinet door.
2. Remove the microphone from the holder by lifting up and then out.
3. While holding the microphone 1 to 2 inches from your mouth, press the mic key and deliver your message.

Paging

Follow these steps to use this system to page:

Units With SKE-ZN4 or -ZN6 Zone Splitter

1. Open the cabinet door.
2. Remove the microphone from the holder by lifting up and then out.
3. Select the zones you wish to communicate to. If ALL-CALL is selected all zones will be activated when the microphone is keyed.
4. While holding the microphone 1 to 2 inches from your mouth, press the mic key and deliver your message.

Units Without Zone Splitter

1. Open the cabinet door.
2. Remove the microphone from the holder by lifting up and then out.
3. While holding the microphone 1 to 2 inches from your mouth, press the mic key and deliver your message.

For Service Contact: _____

Cut Along the Dotted Line



**SILENT
KNIGHT**

by Honeywell

12 Clintonville Road
Northford, CT 06472-1610 USA
203-484-7161
Fax 203-484-7118
www.silentknight.com

© 2009 Honeywell International Inc.